



CU Anschutz Campus-Wide Wayfinding Signs

Project Number: 19-182047

August 14, 2020

ADDENDUM 3

STEP TWO – SHORTLIST BID SOLICITATION – QUESTIONS AND RESPONSES.

1. Can we substitute Mathews with Sherwin Williams (paint samples will be provided)?
 - a. Use the paint manufacturer and color as specified, no color matching will be accepted.
2. Does the 80% requirement for Colorado labor for onsite work only or does it cover manufacturing too?
 - a. The 80% requirement is for work performed on-site. Refer to The Keep Job in Colorado Act FAQ for additional information.
<https://www.colorado.gov/pacific/sites/default/files/KJICA%20FAQs%208-22-16.pdf>
3. Sign type B, B1 & F - Identification names (University of Colorado Anschutz Medical Campus) calls out for 1/2" routed and pushed through copy. "D" Detailed view on sign type F page L8-04 indicates that this can be a rectangle 1/2" push through with vinyl copy overlay. Verify that this would be the case on all 3 sign types.
 - a. The rectangle areas shown are just rough area placeholders. All push-through copy for identification names (top panels of the signs) should be routed with push-through letters that stand proud of the metal panel face. Top panel push through letters to also have the vinyl overlay of either V-1 or V-7, unless otherwise shown with color vinyl overlays. Additional details may be found in the attached Signage Standard.
4. Sign type B, B1 call out for arrows, message area, and (P) as flush mount. The "D" Detail on page L8-02 shows this as a 1/2" push through and indicates that the square, rectangle and round area is the total push through area and not the individual letters. Is this sign area push through or flush mount? And not individual letters routed out but are "round" "rectangle" or "square areas" with vinyl graphics.
 - a. In addition to the response above for top panels, the lower message panels are to be routed and push through acrylic letters that are flush-in with the face of the metal panel. The routed and push through arrows are the actual arrow shape, not a rectangle. The square with round corners and circles for emergency, hospital,

parking, etc. symbols are the actual routed shapes with vinyl overlays. Additional details can be found in the attached Signage Standard.

5. Sign Type F: The supplied RFP drawings do not show a detailed view of the hinged face, how the face mechanisms will allow for insertion or removal of the printed directory, nor does it show how a locking method will work for this hinged area. Will we be allowed to modify some of the sizes in this area of Sign F to allow for a hinging face of our own design that matches the RFP "look".
 - a. The over dimensions of the sign must match the documents. Some minor adjustments to the map insert area may be allowed as necessary to maintain the design intent of the drawings. Access to the map insert area may be through the opening of the full face panel. Changing out the map should not be overly complicated.
 - b. The map insert area should be constructed in a way that prevents water intrusion, prevents condensation build-up in the signage, is easy to clean, will not discolor or turn hazy, and keep the map secured so it doesn't slide down or appear wavy.
 - c. We will look to and work with the signage vendor to propose options to meet the design intent and listed project requirements for this component.
6. What demo, prototype, or mockup samples will be required? Regarding signage mock-ups, can mock-up become part of the work? Are mock-ups to be operational?
 - a. For signage refer to section 10 14 23 Site Wayfinding Signage, 1.6 ACTION SUBMITTALS in the Project Manual.
 - b. In addition to the submittal requirements, section 10 14 23, Part I, Section 1.6, F, 7 – Mock-up should be updated to also include:
 - A fully functional in-place mock-up of each sign type (B, B.1, F) will be required for review and approval before signage vendor should fabricate the remaining signs.
 - The mockup will be reviewed for multiple items including but not limited to construction, quality, finish, illumination, light leakage, and other aesthetics.
 - The in-place mock-up will be accepted as the final deliverable sign for that location as long as all mock-up comments and modifications are fixed/addressed and the sign meets the same quality and design requirements of the other signs.
 - The mockup will be included in the final punch list review if it's accepted by the University to be left in place.
7. Please clearly define GC responsibilities pertaining to testing and inspections. Is GC responsible for costs associated for testing and inspections? Please confirm that the university will hire a third-party inspector.
 - a. Third-party testing and inspection will be performed for all concrete, compaction, and rebar inspections. The University will retain an inspection firm for the Contractor to coordinate and schedule the third-party inspections.
 - b. Third-party inspectors are required to use their time efficiently and will not be allowed to wait around for incomplete work. The general contractor shall make sure work is complete and ready for inspections at their scheduled times.
 - c. The project manager will provide the GC with the testing agency's contact info for scheduling inspections.
 - d. All university building department inspections will be placed by the GC via a website portal.

8. Please clearly define GC responsibilities for permitting and plan review fees. Is GC responsible for costs associated with Building Permit, Electrical, Erosion Control, or Signage Permits? Please confirm that all required permits will be paid for and provided by the University per 00 65 19.01 1.5A.
 - a. The University of Colorado Anschutz Medical Campus is its own Authority Having Jurisdiction on the property where the signage is being installed. The University Project Manager will secure and provide the necessary building permits. The GC will be required to schedule all necessary inspections with the University Building Department. There are no City of Aurora construction or signage permits required for this project.
 - b. There are no signage-specific permits required on University property.
9. Will GC only be permitted to contact with CU SOC contractors only, as typically applicable for CU Boulder projects? If so, may a current list specific to the CU Anschutz campus be provided?
 - a. The CU Anschutz SCPP (small construction purchase program) is our version of CU Boulder's SOC. We request that GCs invite the SCPP contractors to provide a proposal, but you can also solicit proposals from any contractors. The SCPP contractors can be found at <https://www.ucdenver.edu/about/departments/FacilitiesManagement/FacilitiesProjects/Pages/SCPP.aspx>
10. For the existing signs to be relocated, should we assume that the new base meets the same specs as sign types B, B.1, and F? (Sheet L3-04)
 - a. Specifications for relocated signs base should match the new signs.
11. Are we to assume that Sign Type B.1 (alt) would act as a replacement for any nearby new sign on the site map?
 - a. No. Sign Type B.1 (all alternates) will either be a completely new sign where one did not exist before (Alternate Signs 3, 4, 5, 6), or it will replace an existing sign (Alternate signs 1, 2), in which case the existing sign is called out to be demolished.
12. Please confirm if it's the Owner's intent that the awarded signage contractor provide all fabrication and installation in-house. Reviewing the drawings, some of this scope I would intend to have a local (Colorado) partner manufacture. We would also likely contract some of the installations as well based on the schedule of the project.
 - a. This project requires that the signage vendor provide all in-house fabrication and installation with their own employee workforce. No subcontracting, use of non-employees, or 2nd tier subs for manufacturing or installation will be accepted. General Contractor is to vet this requirement of the signage vendors. Signage vendors identified as subcontracting out work will have to be replaced by the GC at no additional cost to the University.
13. If signage vendor is to perform associated trade work turn-key (Concrete foundations, demolition, masonry, Excavation, etc), will they be permitted to using sub-tier contractors for this work?
 - a. The signage vendor should not be providing the associated trade work; concrete foundations, masonry, landscape, demo, etc.
 - b. The GC shall secure bids for each trade.
 - c. The signage vendor scope shall be limited to the fabricated signage scope.

14. Please clarify if signage vendors with local offices can fabricate signage out-of-state.
- a. Signage Vendors with a Colorado office may manufacturer signage out-of-state in their own fabrication facilities.
15. What is the amount per day for liquidated damages?
- a. There are no liquidated damages.
16. Do we need to submit the Subcontractor's Statement of Experience with our bid, or has this already been obtained in short-listing process?
- a. If a signage vendor has been in business for less than 3 years, then a Statement of Experience should be submitted and approved by the University before bid submission. No other vendors for this project need to be submitted for pre-approval.
17. Are we required to turn in a subcontractor list with our bid? If so, may this be sent in the following Monday after bid is due (8/24)?
- a. The Bid form has been updated to include the Subcontractor list, which is due when the bid is submitted. Subcontractor list to be submitted with the bid.
18. Please clarify that Division 33 05 00 and 33 40 00 are limited to the erosion control scope(s) of work. Spec section states to provide permanent storm water quality runoff control ponds. The documents do not appear to show any permanent storm water quality scope(s) of work. Please elaborate on the extent of work related to this spec section.
- a. Division 33 05 00 can be removed from the project scope as it does not pertain.
 - b. Yes, Division 33 40 00 pertains to the erosion control scope for the project. Stormwater control ponds/sumps and permanent stormwater quality devices are not part of the project scope, but all other BMPs and Execution requirements still apply.
19. Are Davis-Bacon Wage Determinations applicable to the project. RE: 00 73 46.
- a. No Davis-Bacon or Prevailing wages are required for this project.
20. "The following specification sections are listed on the Table of Contents but are not included in the documents. Please confirm that these specification sections are not applicable to the project:
- SECTION 017300 EXECUTION
 - SECTION 260000 ELECTRICAL
 - SECTION 260513 MEDIUM-VOLTAGE CABLES
 - SECTION 260543 UNDERGROUND DUCTS & RACEWAYS FOR ELECTRICAL SYSTEMS
 - SECTION 260943 NETWORK LIGHTING CONTROLS
 - SECITON 262000 LOW VOLTAGE ELECTRICALDISTRIBUTION
 - SECTION 262100 MEDIUM VOLTAGE TRANSFORMERS
 - SECTION 262200 LOW VOLTAGE TRANSFORMERS
 - SECITON 262713 ELECTRICAL METERING
 - SECTION 262726 WIRING DEVICES
 - SECTION 263213 DIESEL ENGINE DRIVEN GENERATOR SETS
 - SECITON 263353 STATIC UNINTERRUPTIBLE POWER SUPPLY
 - SECTION 264113 LIGHTING PROTECTION FOR STRUCTURES
 - SECTION 265100 INTERIOR LIGHTING
 - SECTION 265600 EXTERIOR LIGHTING
- a. Attached to this addendum you'll find specification section 01 73 00 – Execution.
 - b. The remainder of the listed specification sections are not applicable.

21. Regarding the unit pricing to be submitted for each sign types, is this inclusive of signage elements only, or shall we include other tradework involved in each individual sign type (Foundations, Masonry, Excavation, Landscaping, Erosion Control, etc.)?
 - a. See the revised bid for unit pricing requirements.
22. Will a licensed arborist be required to supervise work during full duration of project?
 - a. A licensed arborist is not required.
23. Are we able to walk the site with subcontractors prior to the bid? Should we contact CU prior to conducting a site walk, and are badges required for access to certain locations? Are there any Covid-19 policies in place that we must observe?
 - a. GCs can walk (or drive) the campus signage locations and invite subcontractors. CU Anschutz does ask that all individuals follow the University's policies regarding social distancing and wearing of masks any time on campus (including outdoors). Badges are not required while on-campus. Please notify the University Project Manager Ben Bohmann (ben.bohmann@cuanschutz.edu) of any site visits and if available may meet with you at your site visit.
 - b. Please review the University website regarding Corona Virus:
<https://cuanschutz.edu/coronavirus>
<https://cuanschutz.edu/coronavirus/return-to-campus>
24. In advertisement for two-step proposal document, it is mentioned that all excavations on this project are required to be observed by a CABI. What is the extent of GC responsibility in regard to buried asbestos? Shall we include costs for the CABI supervision, and what is the expectation for costs associated with the remediation of asbestos / hazardous materials outside of the required pollution liability insurance?
 - a. CABI observation/supervision is required while excavating.
 - b. No costs are to be carried in the Bid for asbestos or hazardous material remediation except for the pollution liability insurance.
 - c. In the event ACM are identified the University PM should be immediately notified and further excavations in that sign location should be halted. Follow all state and governmental regulations when ACM materials are identified and directions from the CABI.
25. Is the sign fabricator/installer responsible for the structural engineering of the footers, poles and anchor systems or has that already been done/stamped through the architect/designer?
 - a. The design of the sign bases has been reviewed and approved by a structural engineer for the design intent of the signs. If the connection details change then the sign bases will need to be reevaluated. The poles/embed for the signs should be built with the breakaway section as shown in the construction documents.
 - b. The signage vendor will also need to provide engineered stamped drawings for the signs indicating the signs, embeds, and connection details also are structurally sound.
26. Will any off-hours work be required for any of the sign locations? Will there be any work hour restrictions for any of the sign locations?
 - a. In general, work can be performed at any hour. Street/lane/sidewalk closure hours may vary depending on the sign location.

27. Is project still anticipated to start Sept 21, and projected to finish Nov 13th per addendum#2? Early communication with signage contractors regarding lead times for permitting, shop drawings, approved submittals, and fabrication is at least 8-9 weeks before signage elements can be on site ready for install.
- No city permitting is required of the signage vendors.
 - Engineered/stamped shop drawings for the fabricated signage will be required for the signage and connection details. Engineered drawings will be submitted to the University Building Department for review.
 - Contractors can start on-site work earlier than September 12. Coordinate an earlier start date with the project manager. All costs associated with an early start shall be included in the project bid.
 - The contractor should start construction of the sign “bases” and electrical rough-in so that all the bases are complete and waiting for the fabricated signs to arrive.
 - Sign bases should be completed as soon as possible to prevent winter weather-related impacts.
 - The goal is to be completed by Nov 13th.
 - If the Nov 13th delivery date for completion of all signs is a bit tight for 100% completion, the revised project goals are as follows:
 - 100% of all sign bases, electric, landscape/hardscape should be fully complete by Nov 13, 2020, and waiting for fabricated signage to arrive.
 - 50% of the sign locations and fabricated signage should be 100% complete and operational by Nov 13, 2020.
 - The remaining 50% of fabricated signs should be delivered/installed by Nov 30, 2020.

28. Please provide an allowance for landscape repairs and hardscape (sidewalk, curb and gutter, asphalt, etc....) as the quantity cannot not be determined from the construction documents.

- The contractor is to determine how much landscape/hardscape disturbance is necessary for the installation of the signage bases and affiliated work scope. Bids shall include costs necessary to return the landscape/hardscape to original as required to perform the work. The contractor should strive to minimize all disturbance footprints.

29. Which area of campus can be used for material storage?

- The University will provide some lay-down area for storage in the “Rock Lot” along E 23rd Ave between North Ursula Street and Victor Street. Contractor to provide all temp fencing for protection of materials and equipment as this lot is not fenced.
- The area circled in red on the following image is the anticipated lay-down area.



30. Will a parking permit be required to park a work truck on a closed off section of sidewalk?
- a. Parking of vehicles on sidewalks is not allowed since most trucks will not fit on the width of the sidewalk. Parking on sidewalks less than 6 feet wide is never allowed. See traffic closures in the clarification section below.
31. Is there a phasing plan that the University prefers the contractor to follow?
- a. There is no specific phasing plan or order for signage install other than that outlined for completion of the sign bases and landscape. The University will identify the mock-up locations for ease of access and install.
32. Type B sign does not indicate continuous piano style hinges as are indicated in Type B1 and Type F details. What is the intended locking mechanism?
- a. ALL signs should have continuous piano-style hinges on all panels on BOTH faces, not just one face of the sign. The panel will swing open for easy maintenance inside of the sign.
 - b. The locking mechanism is open to input from the signage vendor. We are open to different options. A "concept" locking mechanism is identified in the attachments to show intent.
33. There is a discrepancy in the size of sign type F on page L8-04 (B) is showing the bottom panel to be 1' tall and (D) is showing the bottom panel 1'-11".
- a. The correct dimension is 1' tall.

CLARIFICATIONS.

1. Sidewalk and Street Closures

- a. Closure of sidewalks and lane/streets will require submission of traffic closure requests to the campus traffic control committee along with appropriate traffic control plans at least two weeks in advance of the start of work. Coordinate submission with University Project Manager.
- b. The construction that will require working from roadways or sidewalks shall identify the necessary closures for approval by the traffic control committee.
- c. Weekly attendance at a traffic control meeting is required once the plan is submitted for the duration of traffic closures by the project superintendent and/or GC PM. This meeting is currently being conducted via zoom video conference every Tuesday at 9:30 am.
- d. The traffic committee will accept one closure plan identifying all work locations with a schedule for each lane closures. There may be some locations near the perimeter of campus in high traffic areas that require more specific closure schedules due to volume or time-of-day traffic concerns. Locations shown on sheets L3-01, L3-02, L3-03, L3-07, L3-08, L3-09 are some of the highest traffic volume areas. Signs located closer to the center of campus have less traffic volumes.
- e. The traffic committee will work with the contractor to provide blanket rolling lane closures on University roadways for locations where vehicles can park along the curb and not fully block the direction of traffic. Usage of cones and flashing vehicle warning lights should suffice for rolling lane closures. The locations listed in "d" above typically will not be allowed to block traffic lanes during the peak travel times of 7 am to 9 am and 3 pm to 6 pm.
- f. Typically, a maximum of three vehicles will be allowed to park along the curb on a rolling street closure to supply tools and materials to perform the work. Other vehicles will be required to park in paid visitor lots at appx \$8/day, or monthly permit parking lots at \$35/month in the Rock Lot to \$75/month in gated lots. Monthly

ANSCHUTZ MEDICAL CAMPUS WAYFINDING SIGNAGE

UNIVERSITY OF COLORADO
1945 WHEELING ST. AURORA, CO 80045

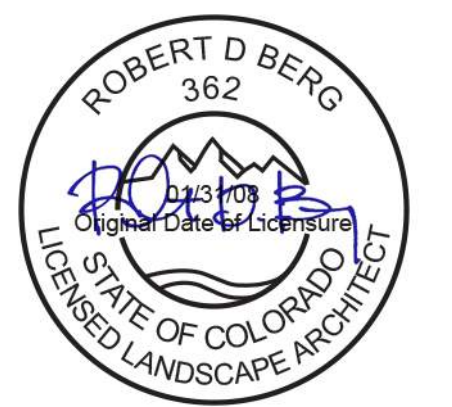

ISSUE DATE: AUGUST 2020

REVISIONS

#	DATE	DESCRIPTION

DRAWN: SB/JP/MS REVIEWED: RB/MS

100% Construction Documents

PROJECT NUMBER: 6346

Sign Type B

SHEET NUMBER

L8-02

COPYRIGHT DESIGNWORKSHOP, INC.

SITE KEYNOTES:

DETAIL / SHEET	RELATED DETAILS
0 / L8-02	0 / L8-01, L8-05
0 / L8-03	0 / L8-01, L8-05
0 / L8-04	0 / L8-01, L8-05
0 / L8-05	0 / L8-01, L8-02, L8-03, L8-04

1.0 SIGN TYPES

1.1	Sign Type B: Multi-Entity Directional
1.2	Sign Type B1: Single-Entity Directional
1.3	Sign Type F: Map/Directory Kiosk
1.4	Base Details for Sign Types B, B1, F

A Plan View 1"=1'-0"

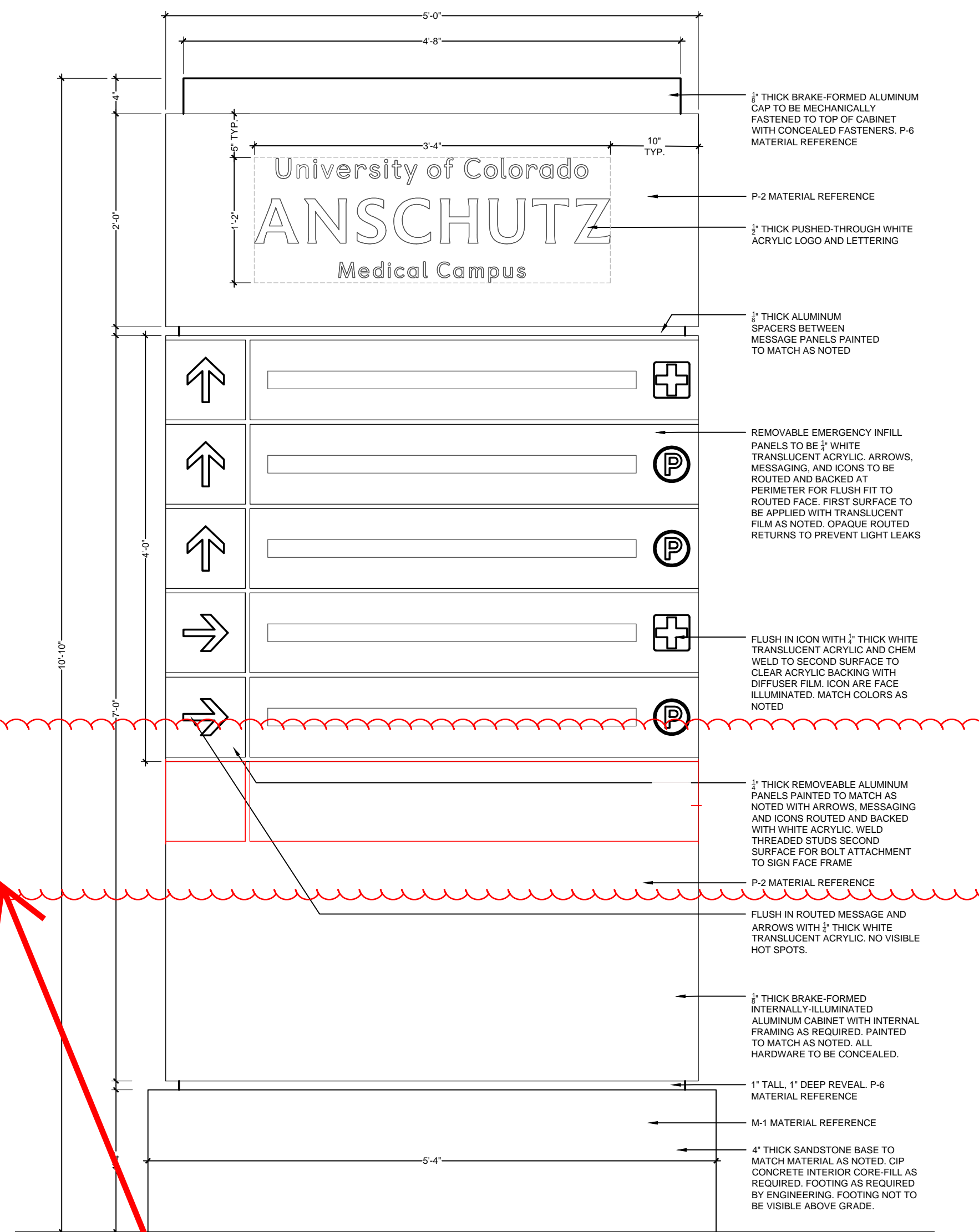

C Side View 1"=1'-0"

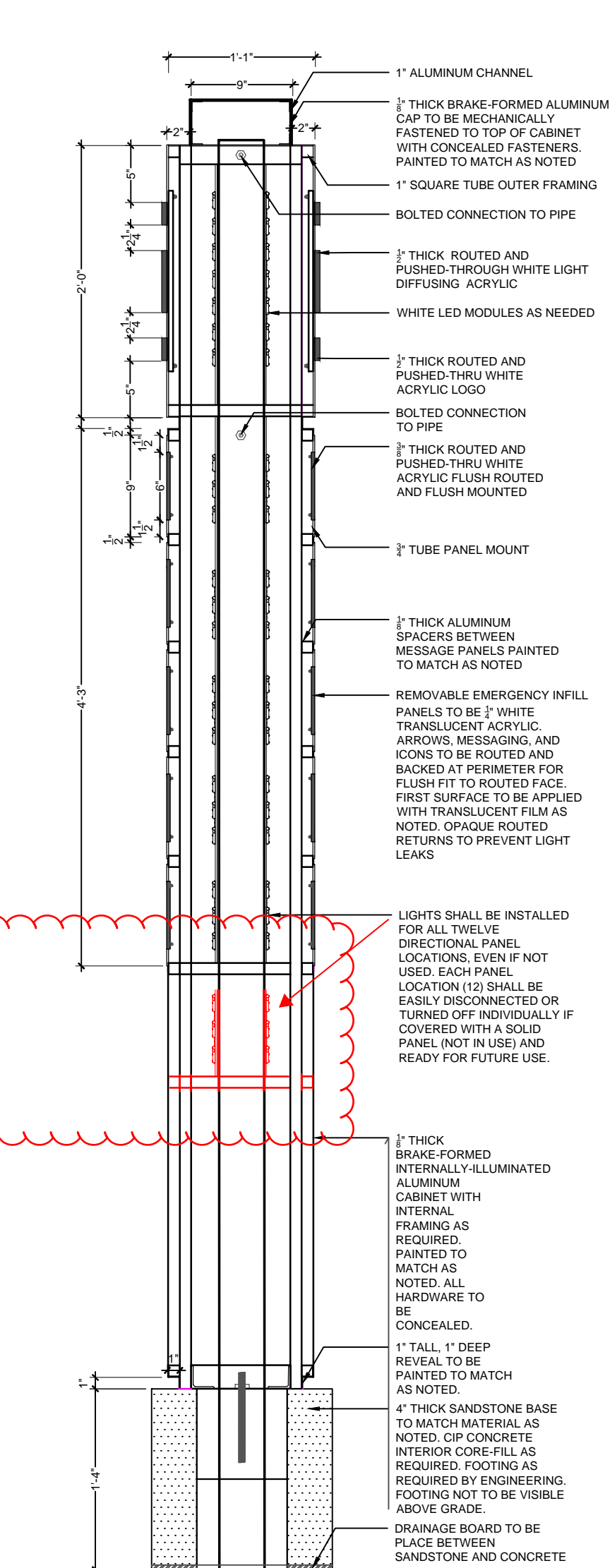

D Detailed Views 1-1/2"=1'-0" / VARIES

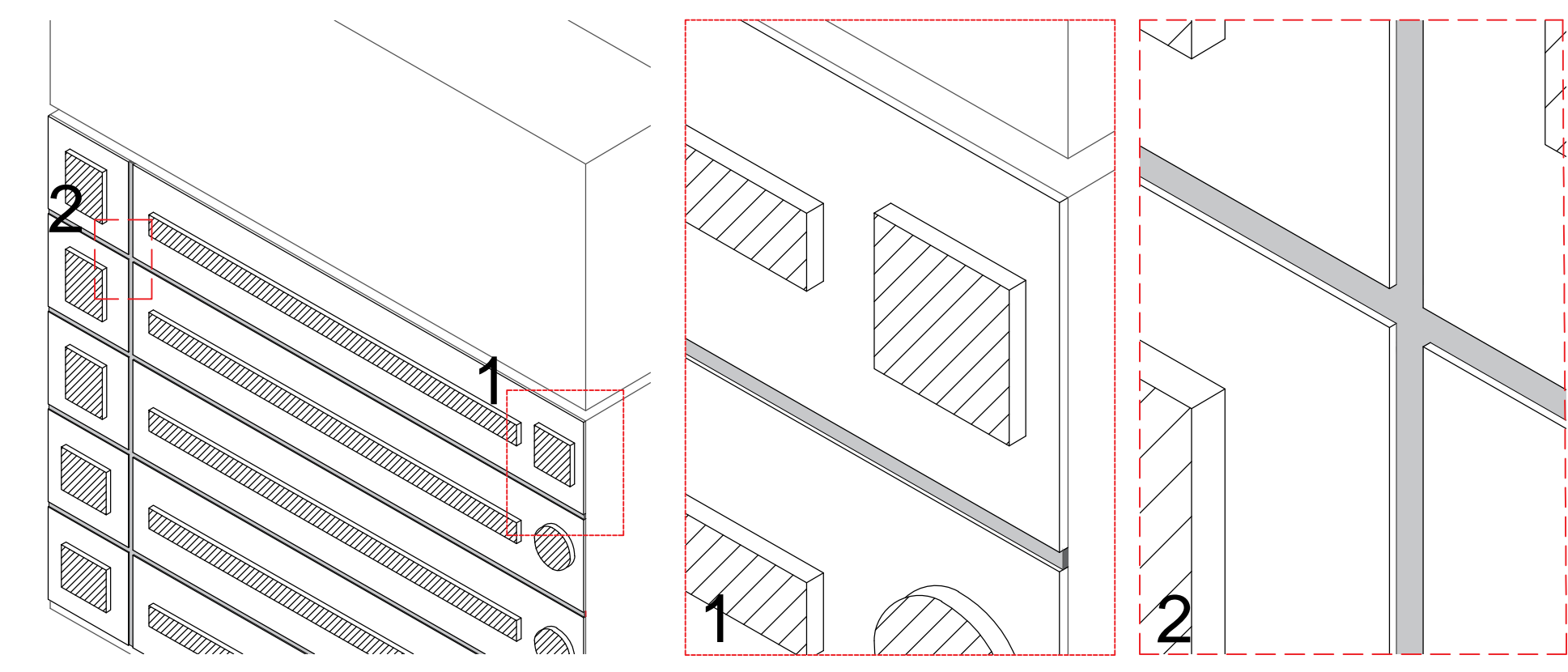

B Elevation 1"=1'-0"

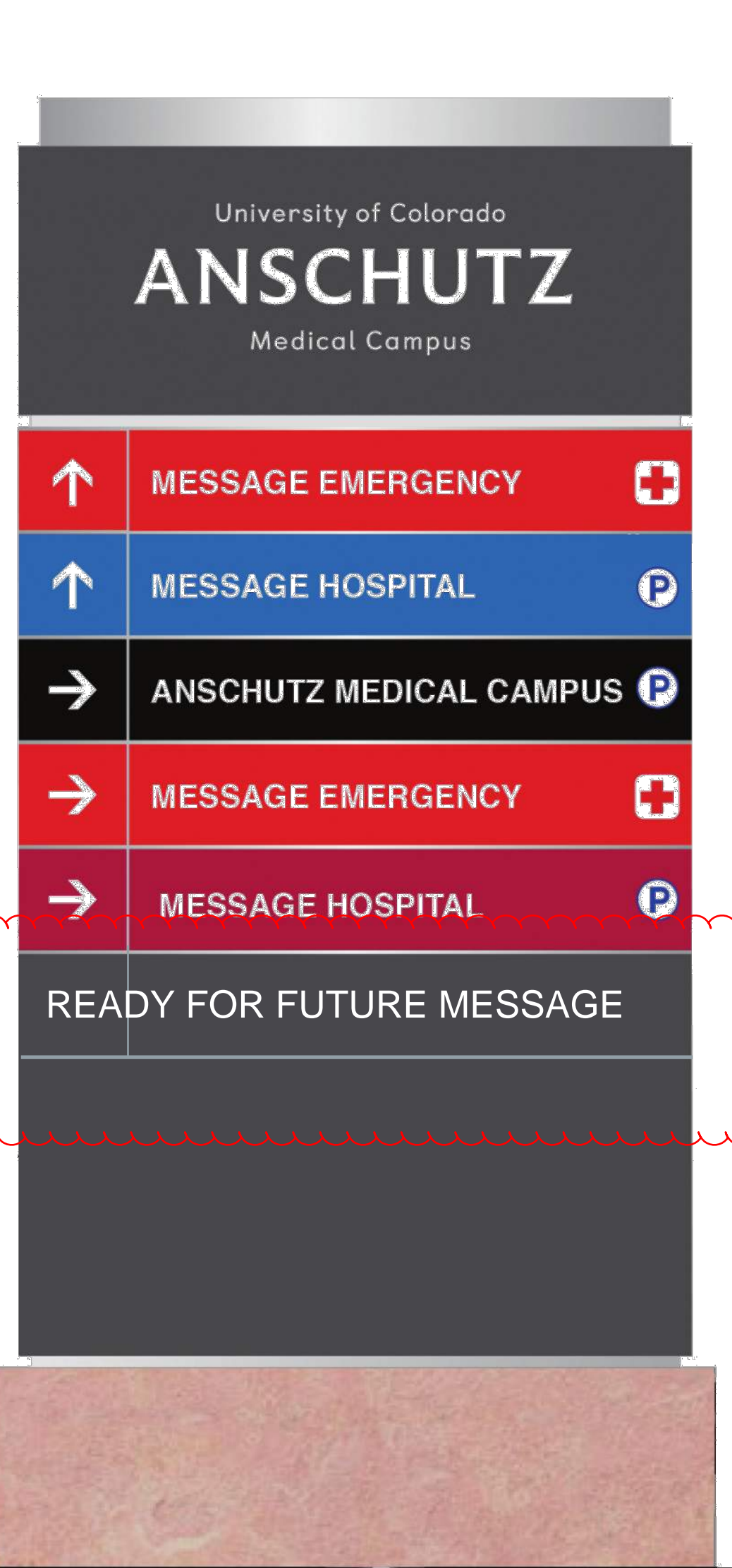

1 Sign Type B: Multi-Entity Directional

TYPE B SIGN TO BE CONSTRUCTION WITH 6 MESSAGE PANEL SECTIONS PER SIDE. UNIVERSITY WILL DETERMINE DURING SHOP DRAWING PHASE IF THE LOWER BLANK MESSAGE PANELS SHOULD BE ONE LARGE PANEL COVERING ALL UNUSED PANELS OR INDIVIDUAL PANELS WITH SPACERS. INTERIOR OF SIGN SHALL BE FULLY SETUP FOR 6 PANEL LOCATIONS PER SIDE.

ADDENDUM #3.

**ANSCHUTZ MEDICAL CAMPUS
WAYFINDING SIGNAGE**
UNIVERSITY OF COLORADO
1945 WHEELING ST. AURORA, CO 80045

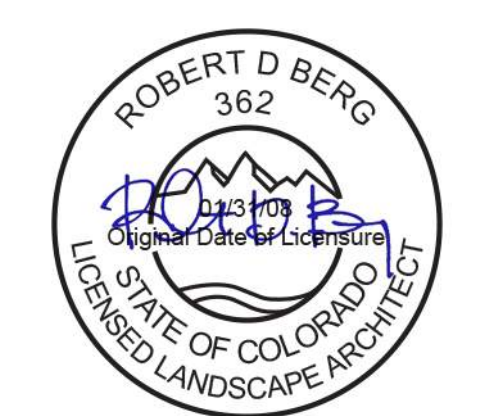

ISSUE DATE: AUGUST 2020

REVISIONS		
#	DATE	DESCRIPTION

DRAWN: SB/JP/MS REVIEWED: RB/MS

100% Construction Documents

PROJECT NUMBER: 6346

Sign Type B1

SHEET NUMBER

L8-03

SITE KEYNOTES:

	DETAIL / SHEET	RELATED DETAILS
1.0 SIGN TYPES		
1.1 Sign Type B: Multi-Entity Directional	0 / L8-02	0 / L8-01, L8-05
1.2 Sign Type B1: Single-Entity Directional	0 / L8-03	0 / L8-01, L8-05
1.3 Sign Type F: Map/Directory Kiosk	0 / L8-04	0 / L8-01, L8-05
1.4 Base Details for Sign Types B, B1, F	0 / L8-05	0 / L8-01, L8-02, L8-03, L8-04

1.0

SIGN TYPES

- 1.1 Sign Type B: Multi-Entity Directional
- 1.2 Sign Type B1: Single-Entity Directional
- 1.3 Sign Type F: Map/Directory Kiosk
- 1.4 Base Details for Sign Types B, B1, F

A Plan View
1"=1'-0"

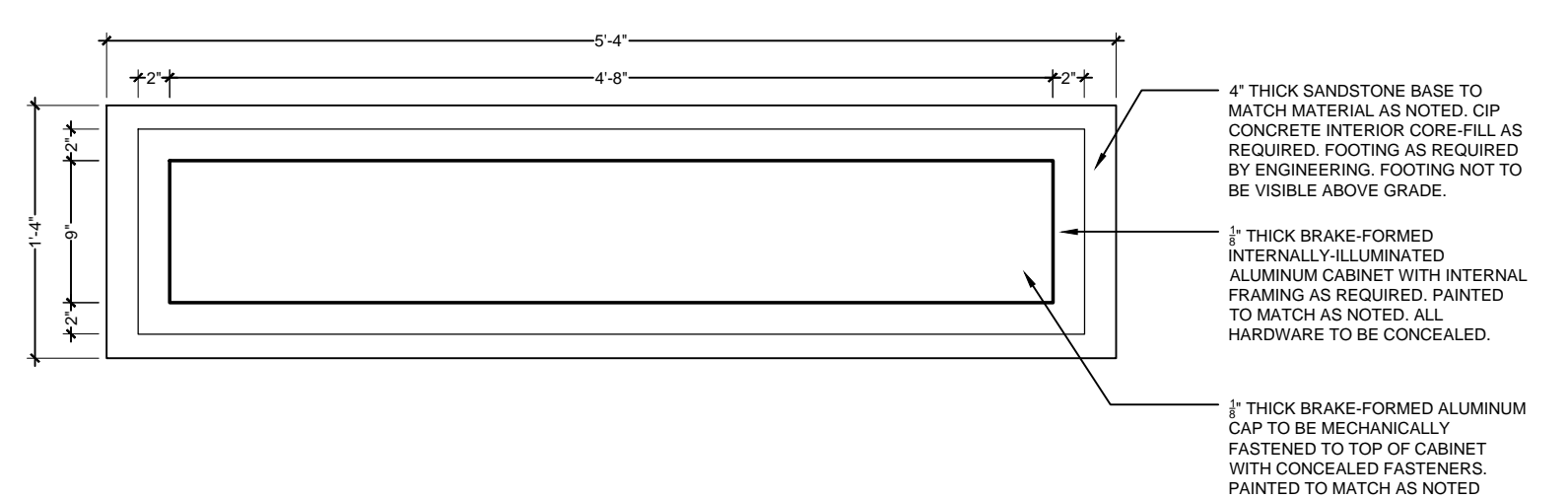

1.2

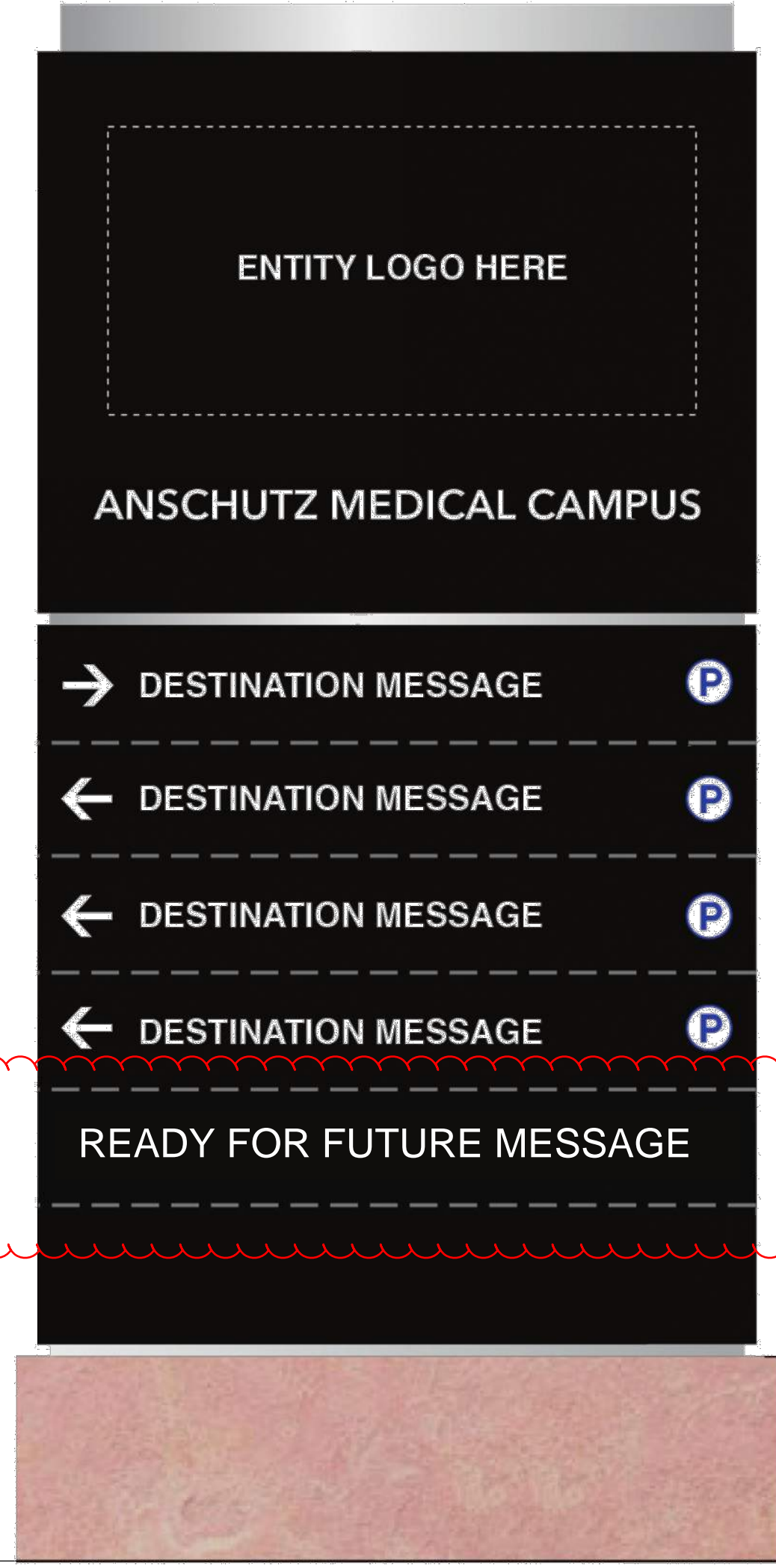

B Elevation
1"=1'-0"

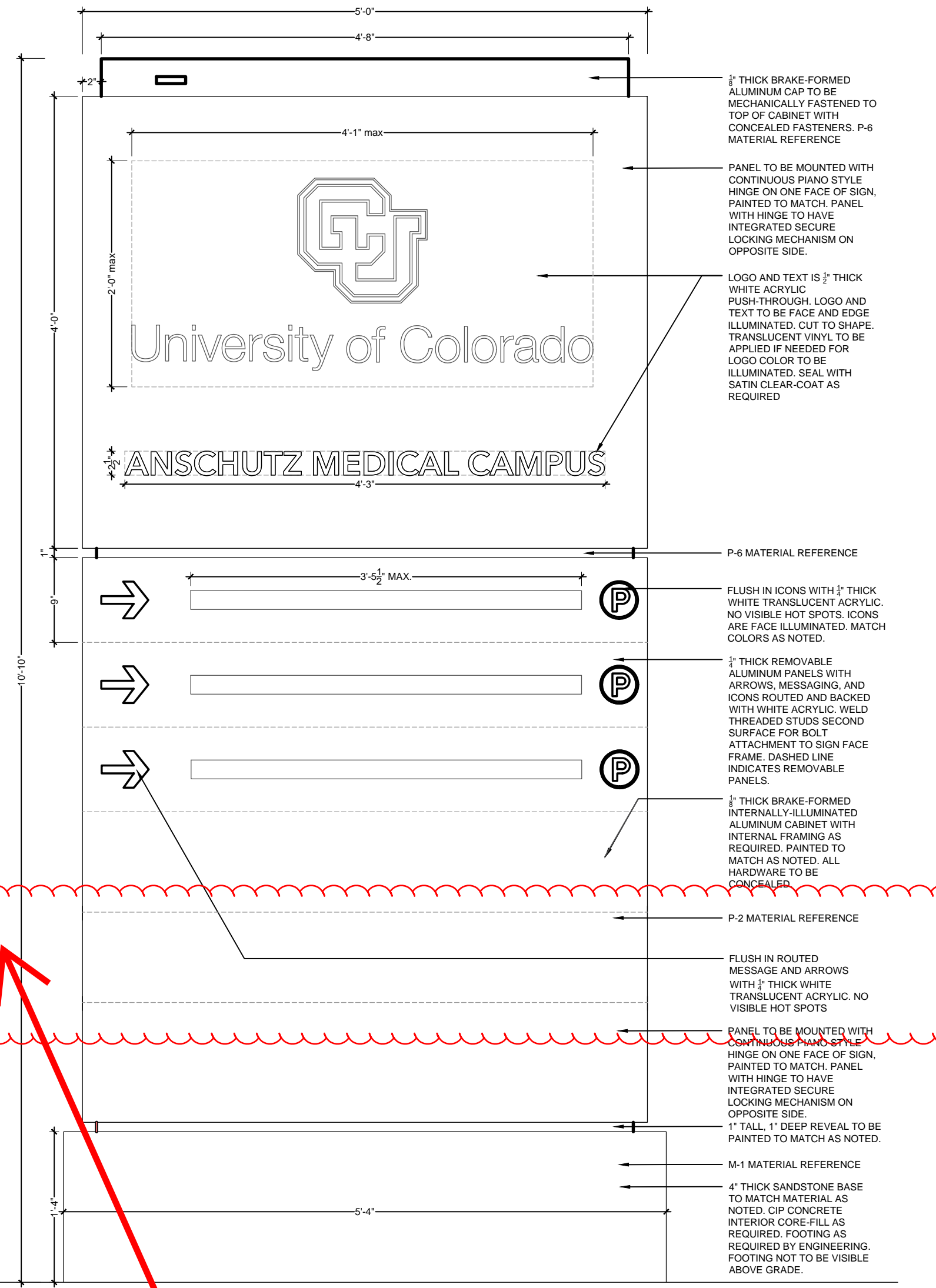

1.2

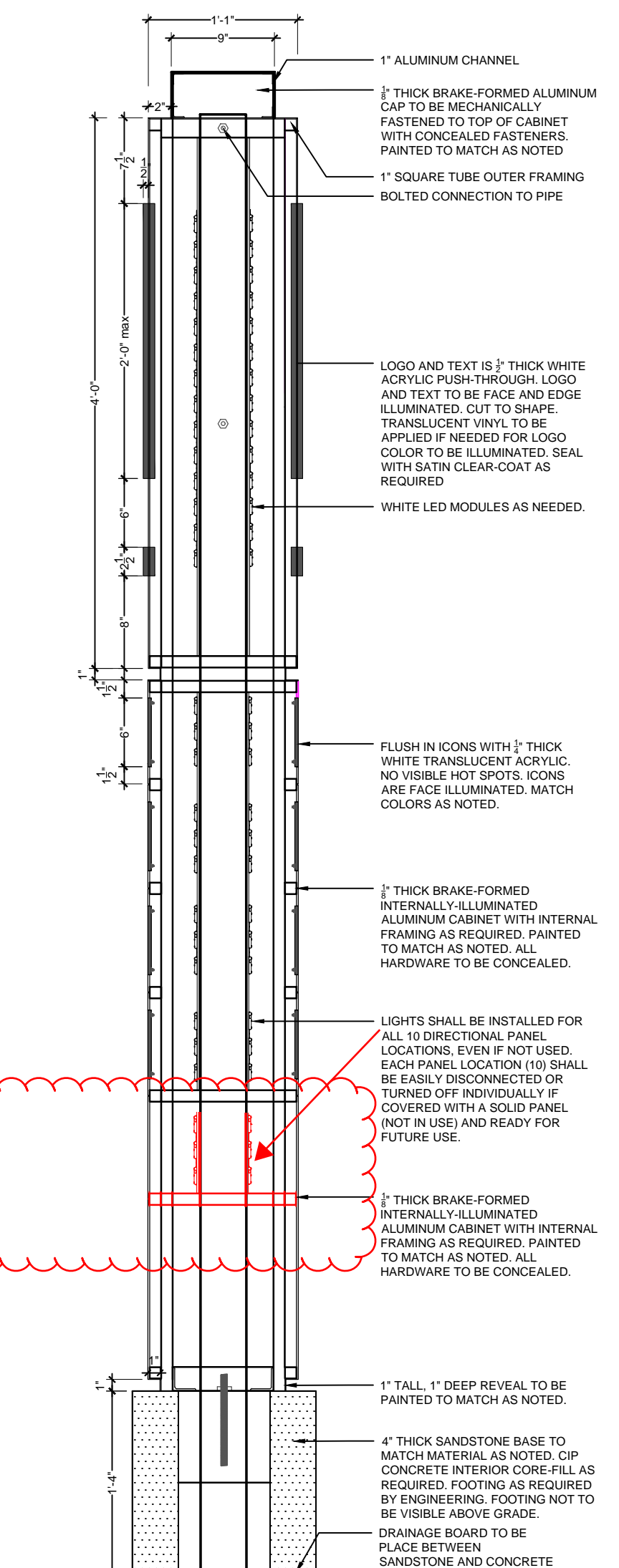

C Side View
1"=1'-0"

1.2

D Detailed Views
1-1/2"=1'-0" / Varies

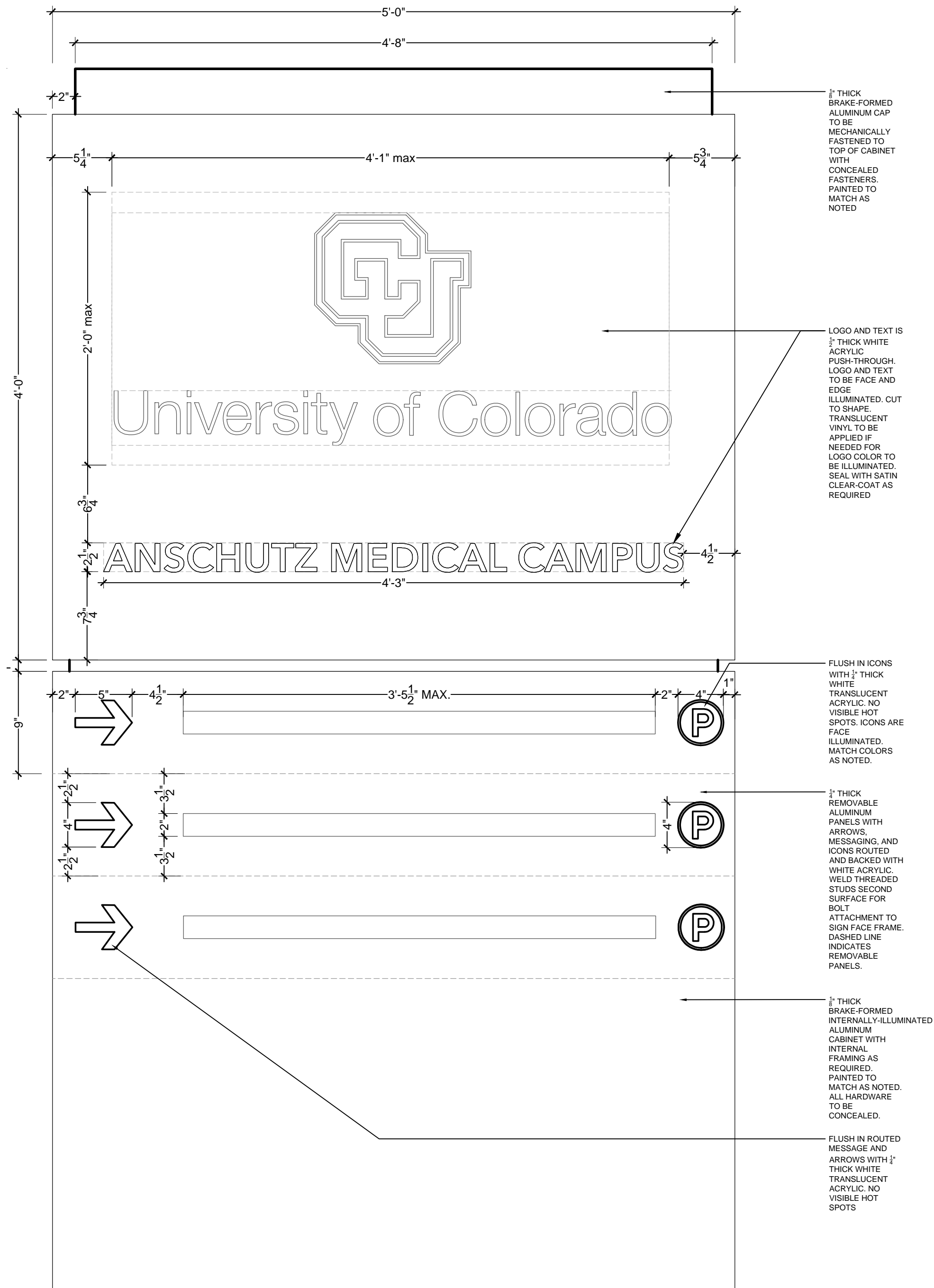

1.2

1 Sign Type B1: Single-Entity Directional
Varies

SIGN TO BE CONSTRUCTION WITH 5 MESSAGE PANEL SECTIONS PER SIDE. UNIVERSITY WILL DETERMINE DURING SHOP DRAWING PHASE IF THE LOWER BLANK MESSAGE PANELS SHOULD BE ONE LARGE PANEL COVERING ALL UNUSED PANELS OR INDIVIDUAL PANELS. INTERIOR OF SIGN TO BE FULLY SETUP AND READY FOR 5 MESSAGE LOCATIONS PER SIDE.

ADDENDUM #3.

Example of piano style hinge on each sign panel.



Example of piano style hinge
on sign panel.



Example of locking mechanism on opposite side of sign.

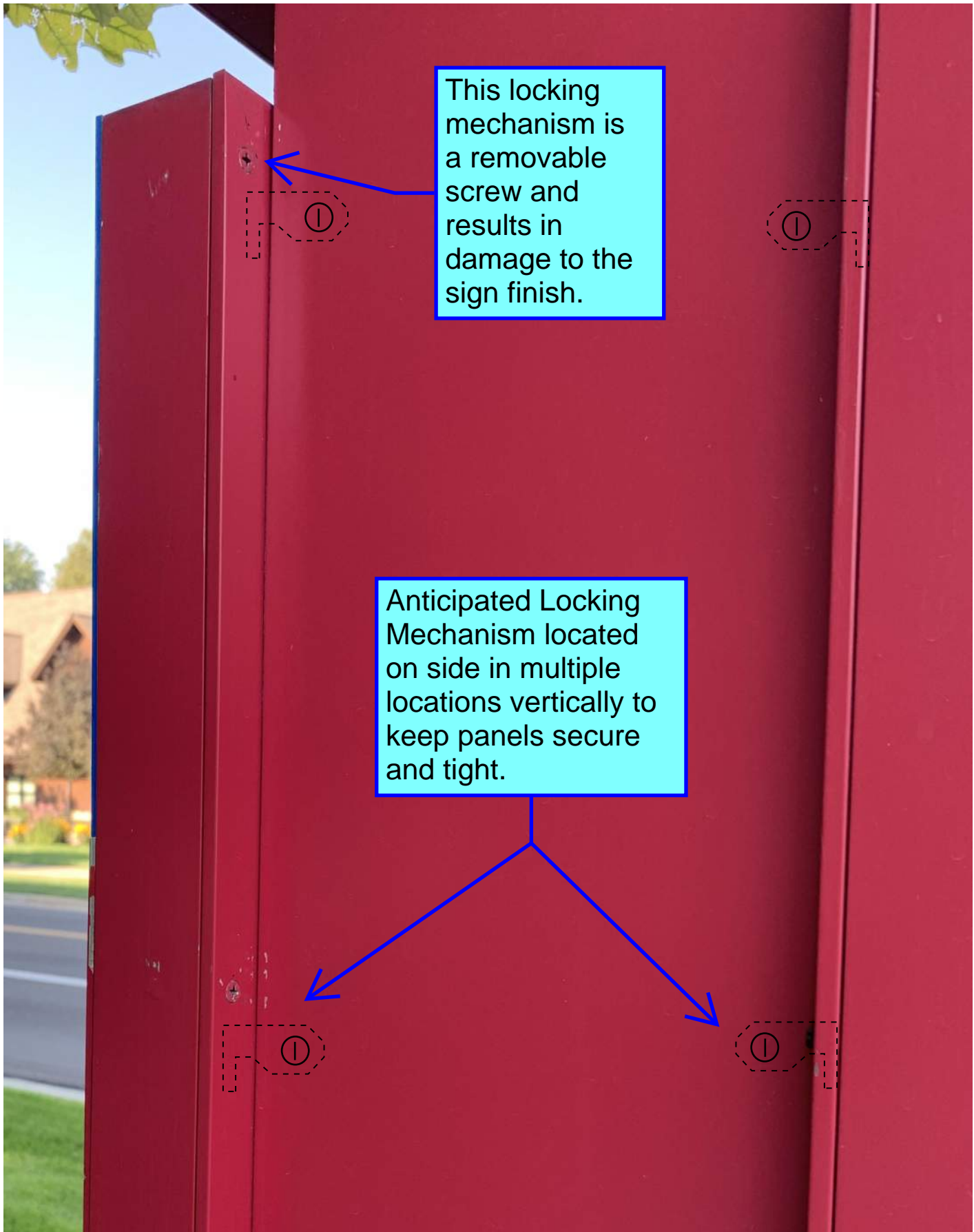

Example of push through lettering and messaging intent.



Example routed push through acrylic symbol with vinyl overlay.

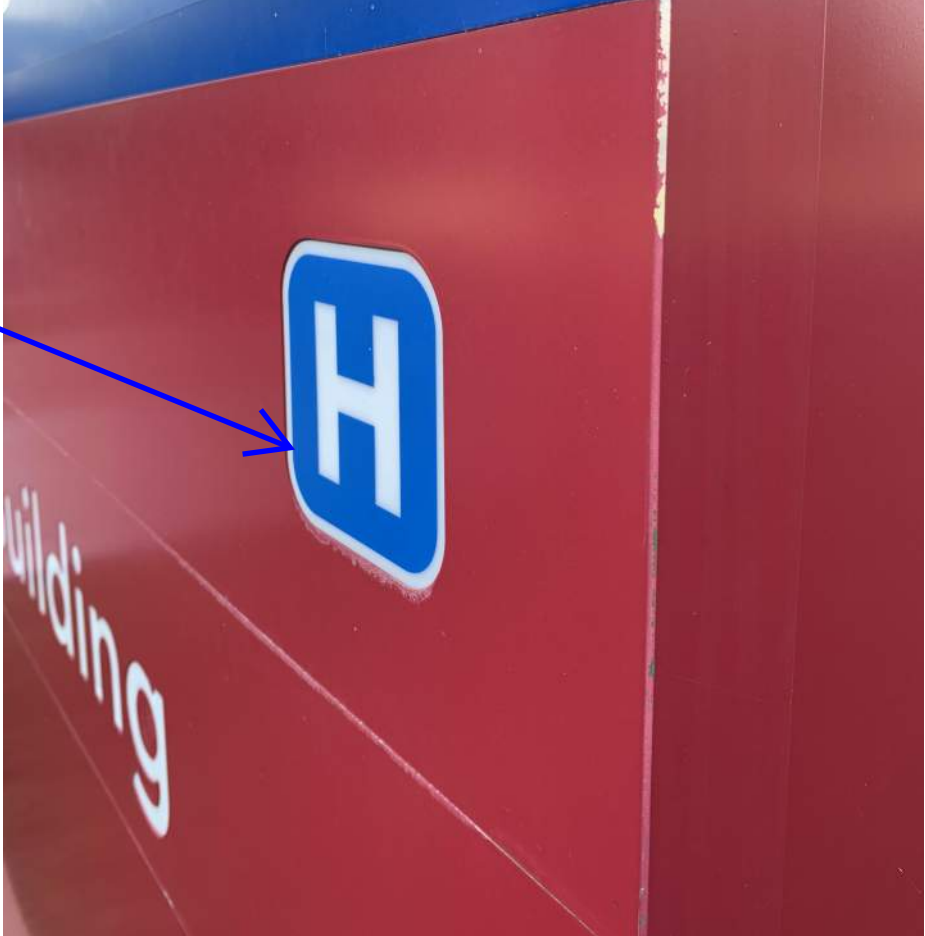

Example of push through lettering and messaging intent.

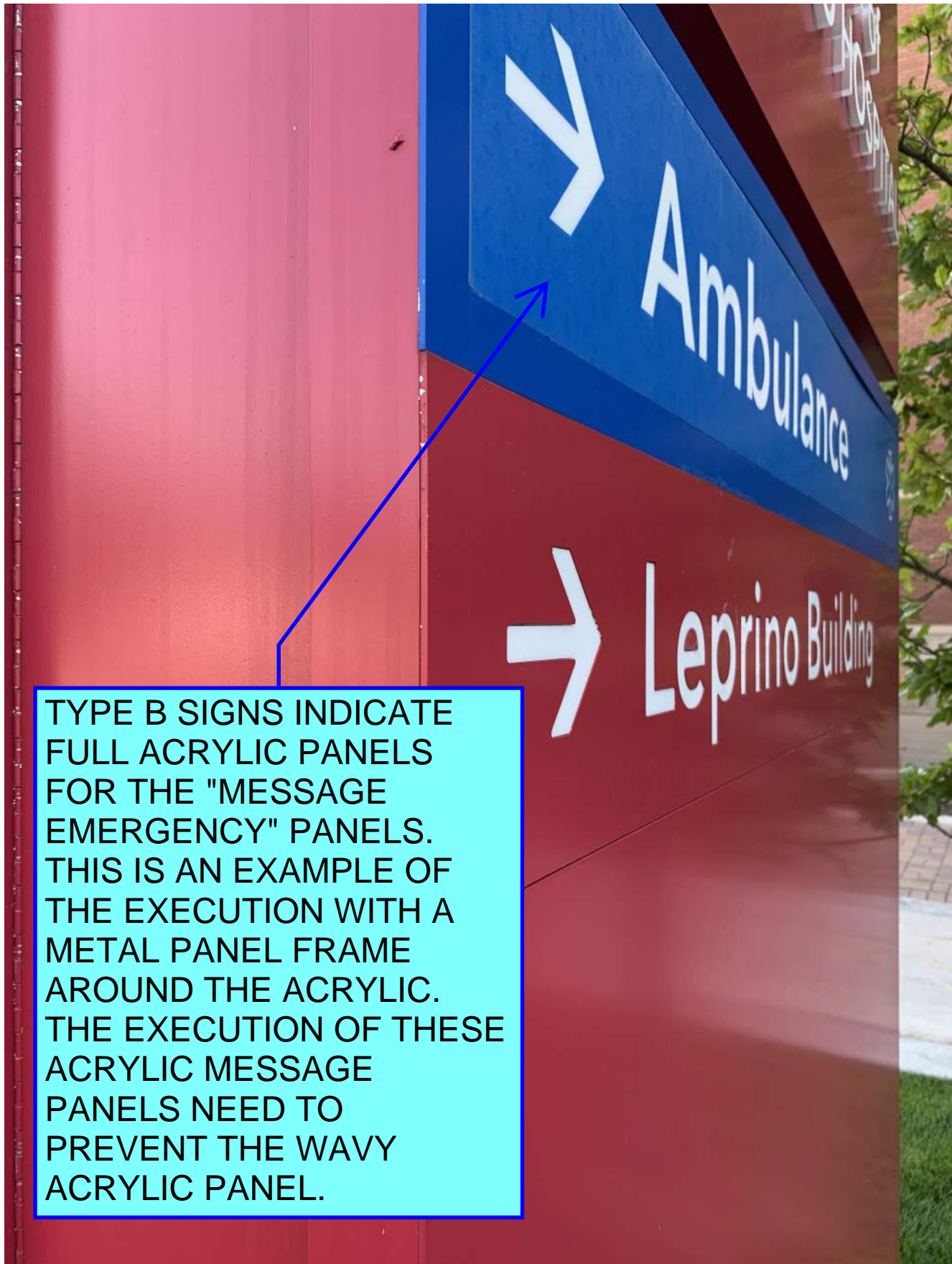

TYPE B SIGNS INDICATE FULL ACRYLIC PANELS FOR THE "MESSAGE EMERGENCY" PANELS. THIS IS AN EXAMPLE OF THE EXECUTION WITH A METAL PANEL FRAME AROUND THE ACRYLIC. THE EXECUTION OF THESE ACRYLIC MESSAGE PANELS NEED TO PREVENT THE WAVY ACRYLIC PANEL.

University of Colorado

ANSCHUTZ

Medical Campus

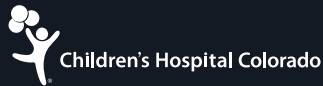

University of Colorado

uchealth

Campus Signage Standards
August 6th 2020 DRAFT

PAGES 2 - 4 NOT APPLICABLE.

Goals for University of Colorado Anschutz Medical Campus

Navigation

Enable visitors and staff to engage and orient themselves within the CU Anschutz Medical Campus. Facilitate travel to and from the hospitals and other important destinations with ease and comfort. CU Anschutz Medical Campus aims to be seamless and cohesive all throughout each entity and single-entities as a whole.

Brand

Unify the brand messaging and aesthetic image of the CU Anschutz Medical Campus through wayfinding and signage.

Experience

Develop and enhance the CU Anschutz Medical Campus visitor experience.

Community

Enhance the sense of place that is evident throughout the Anschutz Medical Campus for staff, visitors, students, and patients.

Signage Materials and Color Palette

Paint & Finishes

All paints and finishes shall match exactly the color, finish, and texture as noted.

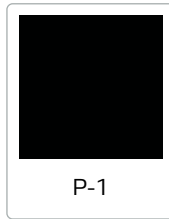

P-1

MP33348
Blackstone



P-2

MP11490
Vanadium Grey

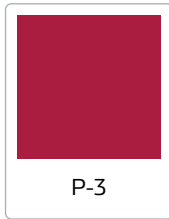

P-3

MP77750
R160308

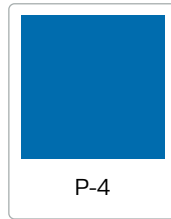

P-4

Painted to match
PMS 2945 C

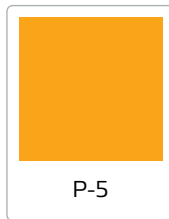

P-5

MP02520
Melon Yellow



P-6

MP180191
Silverstone Metallic



P-7

MP 02110
Cook Islands Blue

Vinyl Colors

All vinyl sheeting shall match exactly the color, finish, and durability of the manufacturers product as noted.

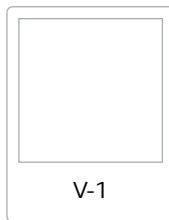

V-1

Avery White
Exterior-grade
vinyl with
10+ year warranty



V-2

Exterior-grade
vinyl to match
PMS 137C with
10+ year warranty

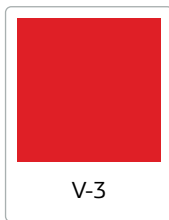

V-3

Exterior-grade
vinyl to match
PMS 2035C with
10+ year warranty

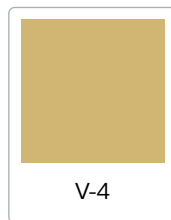

V-4

Exterior-grade
vinyl to match
PMS 466C with
10+ year warranty



V-5

Exterior-grade
vinyl to match
PMS Pro. Black C
with 10+ year
warranty



V-6

Exterior-grade
vinyl to match
PMS 2147C with
10+ year warranty

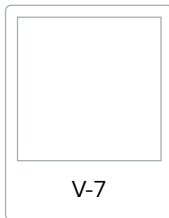

V-7

Avery Clear
Exterior-grade
matte vinyl
with 10+ year
warranty

Other Materials

All materials shall match exactly the color, finish, and durability of the product.



M-1

Lyons Red
Sandstone

Signage Typefaces and Symbols

Typefaces

Each typeface below serves a particular purpose for signage and are noted in each sign type drawing. The following typefaces shall be used for all messaging on signage on the CU Anschutz Medical Campus:

**ABCDEFGHIJKLMNOPQRSTUVWXYZ
abcdefghijklmnopqrstuvwxyz 1234567890**

Font Name: Helvetica
Weight: Bold

ABCDEFGHIJKLMNOPQRSTUVWXYZ
abcdefghijklmnopqrstuvwxyz 1234567890

Font Name: Helvetica
Weight: Medium Condensed

ABCDEFGHIJKLMNOPQRSTUVWXYZ
abcdefghijklmnopqrstuvwxyz 1234567890

Font Name: Helvetica
Weight: Regular

ABCDEFGHIJKLMNOPQRSTUVWXYZ
abcdefghijklmnopqrstuvwxyz 1234567890

Font Name: Helvetica
Weight: Light Condensed

ABCDEFGHIJKLMNOPQRSTUVWXYZ
abcdefghijklmnopqrstuvwxyz 1234567890

Font Name: Castledown
Weight: Regular

**ABCDEFGHIJKLMNOPQRSTUVWXYZ
abcdefghijklmnopqrstuvwxyz 1234567890**

Font Name: FS Benjamin
Weight: Bold

ABCDEFGHIJKLMNOPQRSTUVWXYZ
abcdefghijklmnopqrstuvwxyz 1234567890

Font Name: Avenir Next
Weight: Demi Bold

Symbols

The following symbols shall be used for all signage on the CU Anschutz Medical Campus:

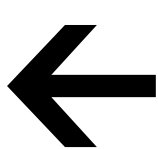

University of Colorado
ANSCHUTZ
Medical Campus

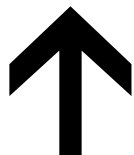

University of Colorado
ANSCHUTZ
Medical Campus



Children's Hospital Colorado
UNIVERSITY OF COLORADO ANSCHUTZ MEDICAL CAMPUS



UNIVERSITY OF COLORADO ANSCHUTZ MEDICAL CAMPUS

ANSCHUTZ MEDICAL CAMPUS

BLANK







Design Intent Statement

The Campus Signage Standards shall:

- Clearly, concisely and consistently communicate, providing identification, regulatory and operational information
- Perpetuate the identity and University of Colorado Denver Anschutz Medical Campus/ University of Colorado Hospital / The Children’s Hospital Colorado by conveying established graphic standards for logo, shape, colors and typography
- Provide a vehicle with which to distinguish various portions of the campus, using shape, color or other means of coding
- Complement the established palette of architectural and landscape materials and colors, provide tools with which those navigating through the campus may establish and maintain their orientation to the campus, by reinforcing their proximity to campus landmarks
- Shall establish prescriptive guidelines for present and future implementation of campus signage
- Reflect a sense of quality and community
- Accommodate and enhance existing and future programs and needs of those navigating through the campus, while remaining sensitive to the site and environment
- Be durable, economical and aesthetically enduring, designed to accommodate future growth and change
- Create a hierarchy of signs that communicate directions to campus landmarks, thereby requiring fewer signs to properly direct those navigating through the campus
- Be appropriately designed for both daytime and nighttime functions

PAGES 10 - 12 NOT APPLICABLE.

Sign Type [REDACTED]

	Purpose	Geometry	Maximum Width	Maximum Height	Message Fields	Locations
						

B
Multi-Entity
Directional

To serve as a wayfinding to all entities on campus

Vehicular-focused wayfinding sign with an aluminum cap and sandstone base

Double-sided (2) internally-illuminated sign with a 5'-4" wide maximum

Double-sided (2) sign with a 10'-10" tall maximum

CU Anschutz Medical Campus logo and directional information to all entities

At the main decision points to navigate to all entities.

--	--	--	--	--	--	--

B.1
Single-Entity
Directional

To serve as a wayfinding for single-entities only

Vehicular-focused wayfinding sign with an aluminum cap and sandstone base

Double-sided (2) internally-illuminated sign with a 5'-4" wide maximum

Double-sided (2) sign with a 10'-10" tall maximum

CU Anschutz Medical Campus logo and directional information for single entity

At the main decision points to navigate to single-entity destinations

--	--	--	--	--	--	--

						
--	---	---	---	--	---	---

--	--	--	--	--	--	--



Sign Type Allowances

Purpose	Geometry	Maximum Width	Maximum Height	Message Fields	Locations
---------	----------	---------------	----------------	----------------	-----------

[Redacted]	[Redacted]	[Redacted]	[Redacted]	[Redacted]	[Redacted]
------------	------------	------------	------------	------------	------------

[Redacted]	[Redacted]	[Redacted]	[Redacted]	[Redacted]	[Redacted]
------------	------------	------------	------------	------------	------------

[Redacted]	[Redacted]	[Redacted]	[Redacted]	[Redacted]	[Redacted]
------------	------------	------------	------------	------------	------------

[Redacted]	[Redacted]	[Redacted]	[Redacted]	[Redacted]	[Redacted]
------------	------------	------------	------------	------------	------------

F Map/Kiosk	To serve as a wayfinding for mostly pedestrians once their car is parked.	Pedestrian-focused wayfinding signage with an "i" icon on top of sign and a sandstone base	Double-sided (2) internally-illuminated sign with a 4'-0" wide maximum	Double-sided (2) sign with a 8'-4 1/2" tall maximum	CU Anschutz Medical Campus logo and campus map of nearby building radius	At the entrances of main parking lots for pedestrian-oriented wayfinding
-----------------------	---	--	--	---	--	--

[Redacted]	[Redacted]	[Redacted]	[Redacted]	[Redacted]	[Redacted]
------------	------------	------------	------------	------------	------------

[Redacted]	[Redacted]	[Redacted]	[Redacted]	[Redacted]	[Redacted]
------------	------------	------------	------------	------------	------------

[Redacted]	[Redacted]	[Redacted]	[Redacted]	[Redacted]	[Redacted]
------------	------------	------------	------------	------------	------------

[Redacted]

ACQUISITION

PAGES 15 - 18 NOT APPLICABLE.

B Sign Type B: Multi-Entity Directional

- 1 4" thick sandstone base to match material as noted. CIP concrete interior core-fill as required. Footing as required by engineering. Footing not to be visible above grade.

- 2 1/8" thick brake-formed internally-illuminated aluminum cabinet with internal framing as required. Painted to match as noted. All hardware to be concealed.
- 3 1" tall, 1" deep reveal to be painted to match as noted.

Note: All wayfinding messaging shown below are placeholder text and each entity is responsible for providing accurate messaging.

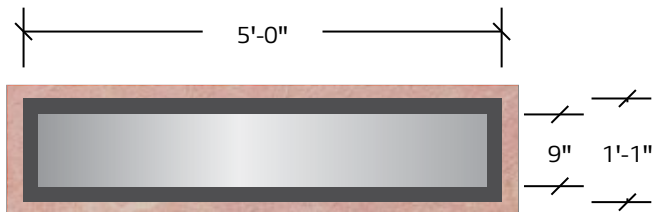

1 Sign Type B: Multi-Entity Directional - Plan View
Scale: 1/2" = 1' - 0"

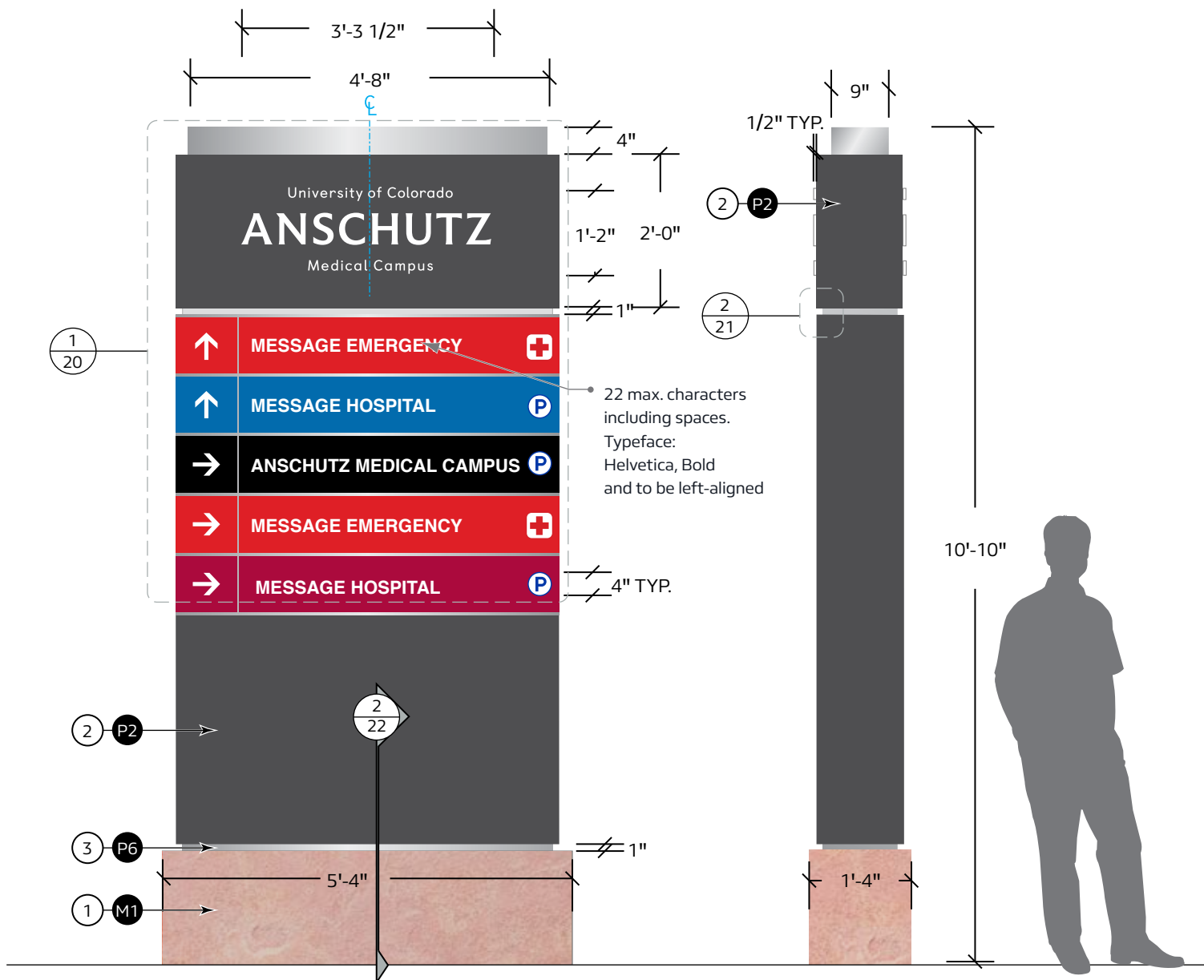

2 Sign Type B: Multi-Entity Directional
Scale: 1/2" = 1' - 0"

3 Sign Type B: Multi-Entity Directional - Side View
Scale: 1/2" = 1' - 0"

B Sign Type B: Multi-Entity Directional

- ① 1/8" thick brake-formed aluminum cap to be mechanically fastened to top of cabinet with concealed fasteners. Painted to match as noted.
- ② 1/2" thick push-through white acrylic logo and lettering.
- ③ 1/8" thick aluminum spacers between message panels painted to match as noted.
- ④ Removable emergency infill panels to be .25" white translucent acrylic. Arrows, messaging, and icons to be routed and backed at perimeter for flush fit to routed face. First surface to be applied with translucent film as noted. Opaque routed returns to prevent light leaks.
- ⑤ 1/4" thick removable aluminum panels painted to match as noted with arrows, messaging, and icons routed and backed with white acrylic. Weld threaded studs second surface for bolt attachment to sign face frame.
- ⑥ Flush in routed message and arrows with 1/4" thick white translucent acrylic, No visible hot spots.
- ⑦ Flush in icon with 1/4" thick white translucent acrylic and chem weld to second surface to clear acrylic backing with diffuser film. Icon are face illuminated. Match colors as noted.

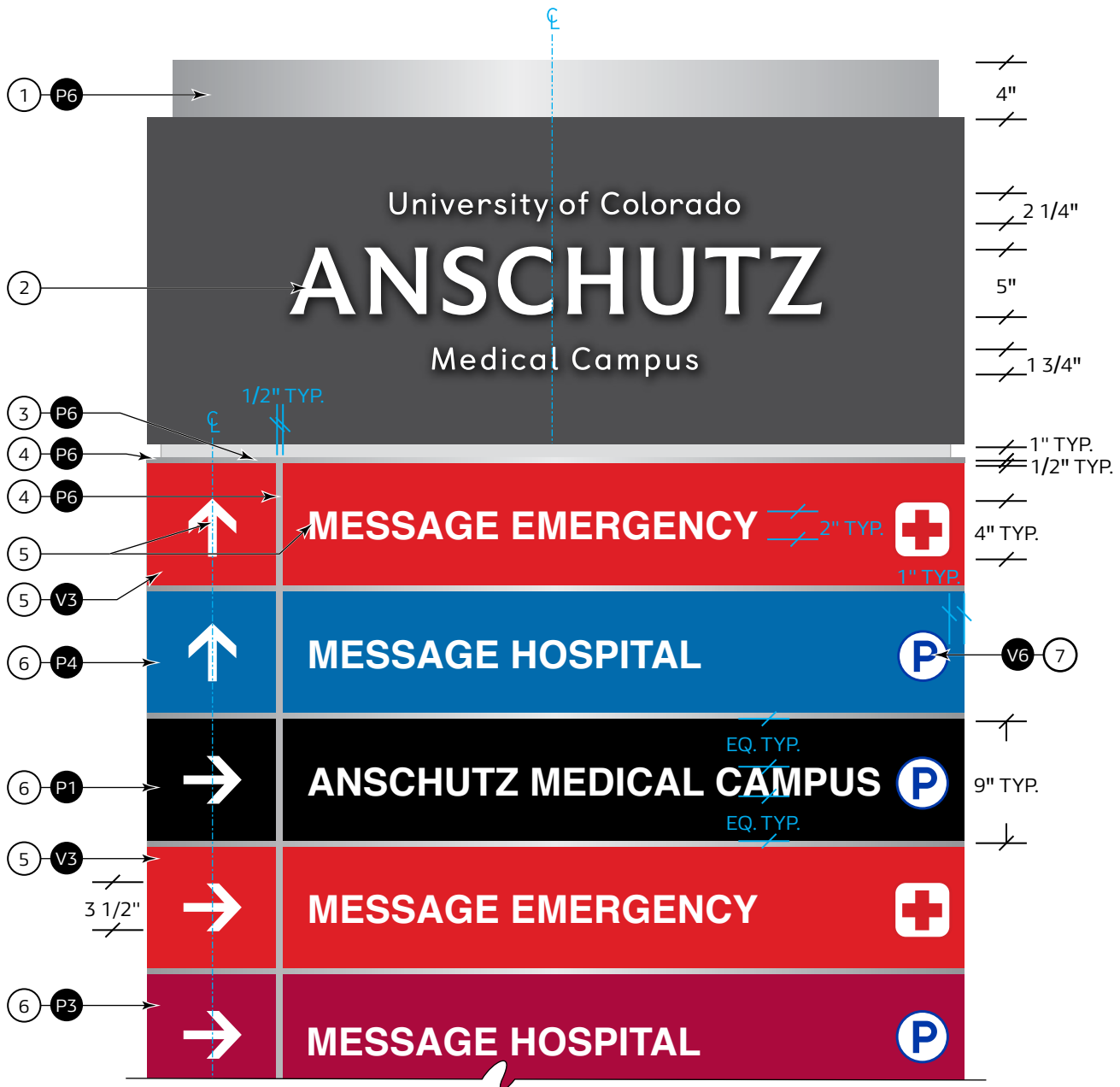

① Sign Type B: Multi-Entity Directional - Detail View
 - Scale: 1" = 1' - 0"

B Sign Type B: Multi-Entity Directional

- 1 1" tall, 1" deep reveal to be painted to match as noted.



1 Sign Type B: Illuminated Intent - Isometric View
- Scale: NTS

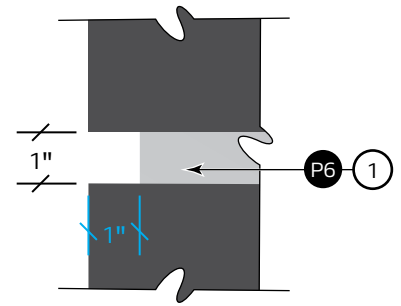

2 Sign Type B: Reveal Detail View
- Scale: 3" = 1' - 0"

B B.1 C D Base Detail

- ① 4" diameter standard pipe to top of sign cabinet.
- ② 8" CIP concrete interior core-fill as required. Top of block shall be above stone.
- ③ 4" thick sandstone base to match material as noted.
- ④ Spacer to be placed between sandstone and concrete.
- ⑤ 5'-4" x 1'-4" Concrete footing set top of footing below final grade. (1) row of #4 rebar both directions at 12" on center.
- ⑥ (4) #4 rebar vertical in caisson.
- ⑦ 16" diameter concrete caisson.

Refer to construction documents for additional base construction details.

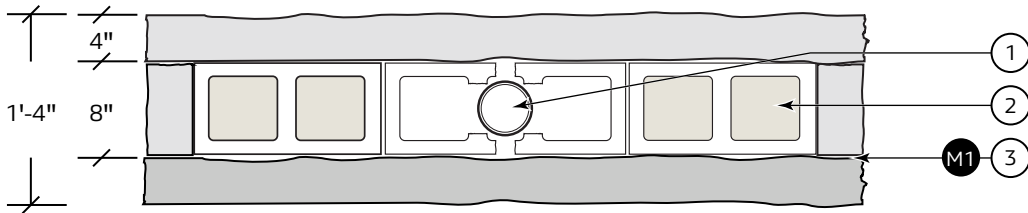

① Sign Types B, B.1, C, D - Sandstone Base Detail Plan View
 - Scale: 3/4" = 1' - 0"

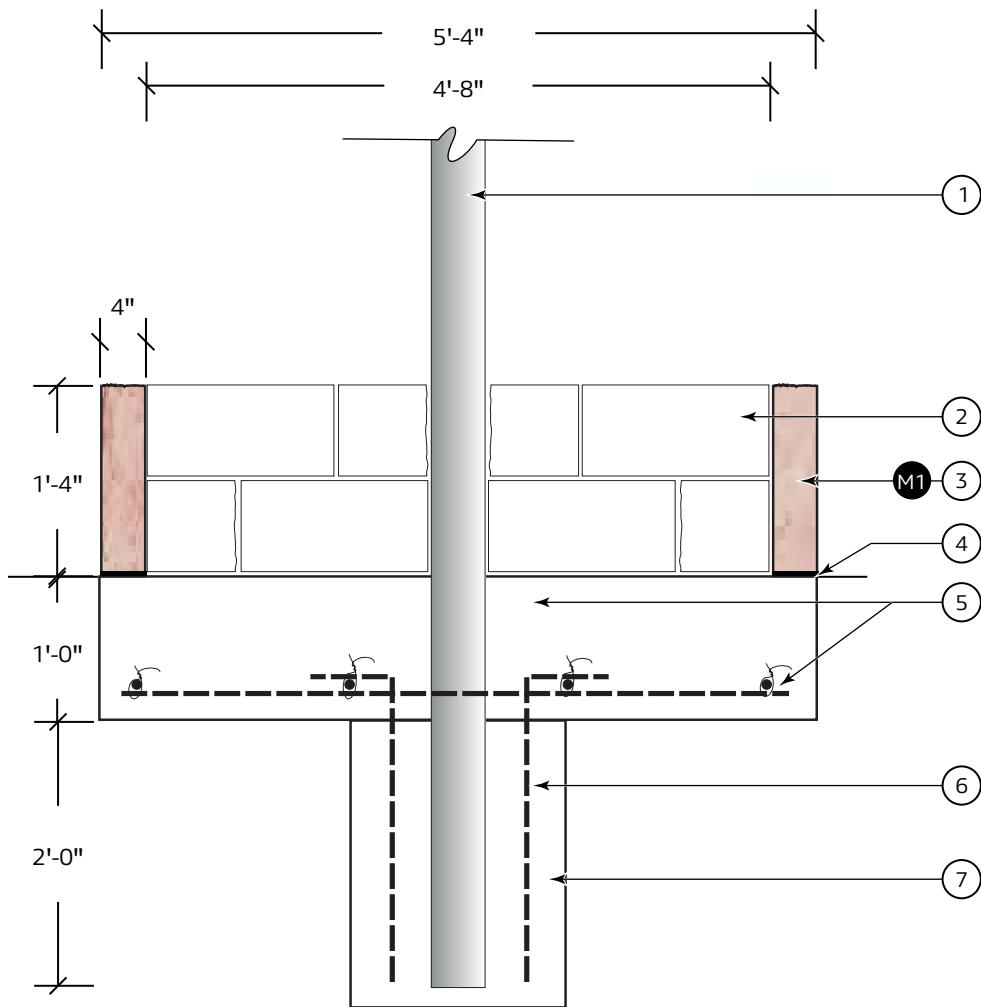

② Sign Types B, B.1, C, D - Section View through Front Elevation
 - Scale: 3/4" = 1' - 0"

B.1 Sign Type B.1: Single-Entity Directional

- ① 4" thick sandstone base to match material as noted. CIP concrete interior core-fill as required. Footing as required by engineering. Footing not to be visible above grade.

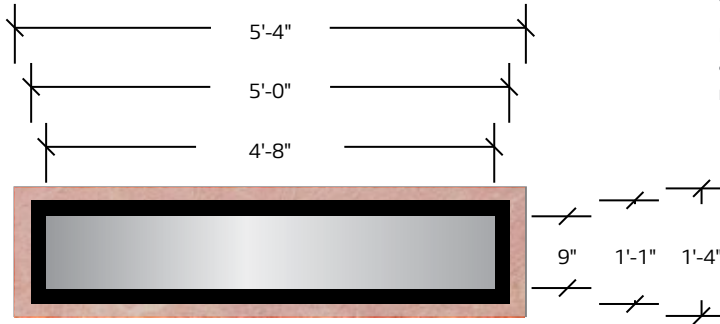

- ② 1/8" thick brake-formed internally-illuminated aluminum cabinet with internal framing as required. Painted to match each entity's main brand color. All hardware to be concealed.
- ③ 1" tall, 1" deep reveal to be painted to match as noted.

Note: All wayfinding messaging shown below are placeholder text and each entity is responsible for providing accurate messaging.

① Sign Type B.1: Single-Entity Directional - Plan View
Scale: 1/2" = 1' - 0"

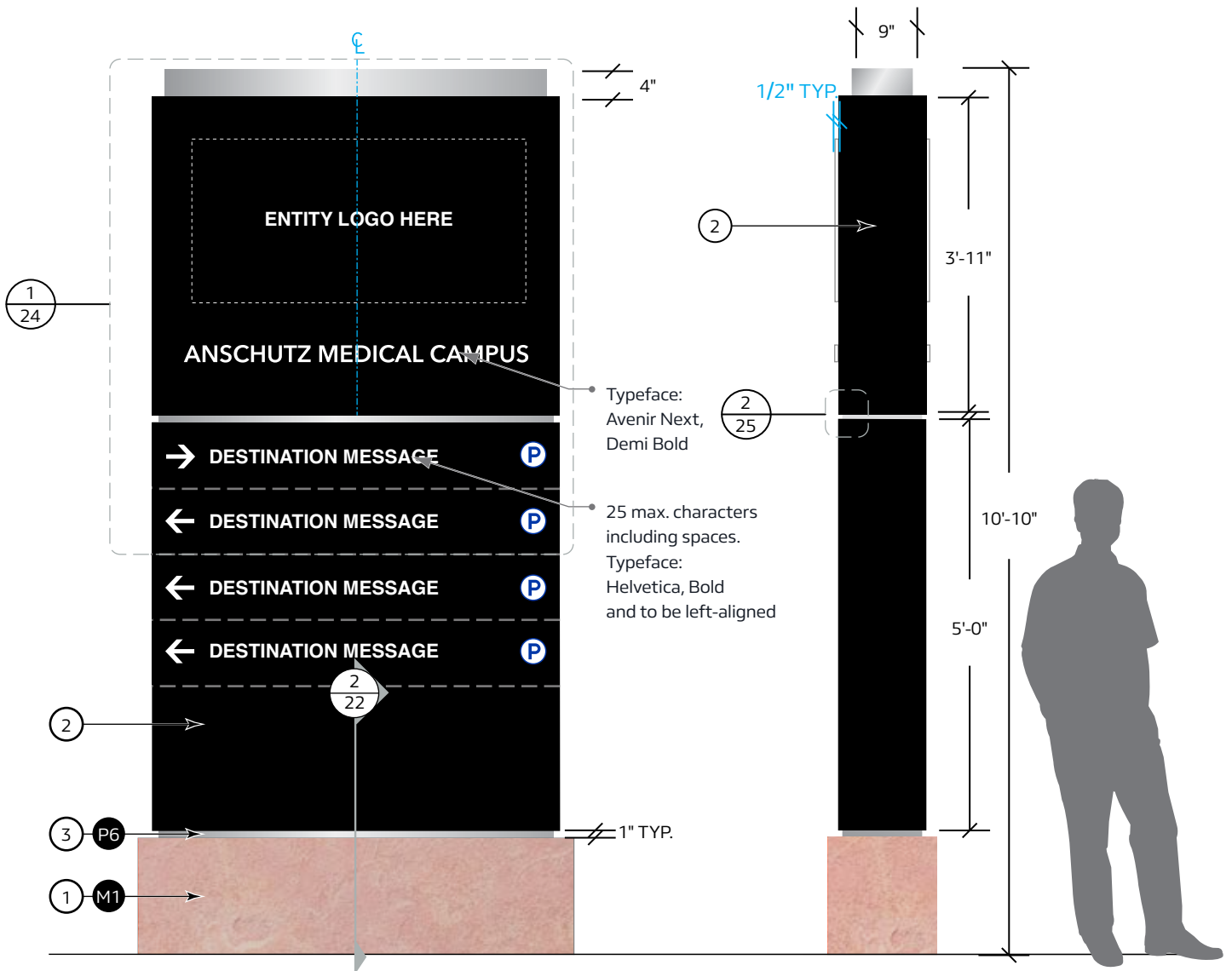

② Sign Type B.1: Single-Entity Directional
Scale: 1/2" = 1' - 0"

③ Sign Type B.1: Single-Entity Directional - Side View
Scale: 1/2" = 1' - 0"

B.1 Sign Type B.1: Single-Entity Directional

- ① 1/8" thick brake-formed aluminum cap to be mechanically fastened to top of cabinet with concealed fasteners. Painted to match as noted.
- ② Logo and text is 1/2" thick white acrylic push-through. Logo and text to be face and edge illuminated. Cut to shape translucent vinyl to be applied if needed for logo color to be illuminated. Seal with satin clear-coat as required.
- ③ 1/4" thick removable aluminum panels with arrows, messaging, and icons routed and backed with white acrylic and backed with white acrylic. Weld threaded studs second surface for bolt attachment to sign face frame. Grey dotted line indicates removable panels.
- ④ Flush in routed message and arrows with 1/4" thick white translucent acrylic. No visible hot spots.
- ⑤ Flush in icons with 1/4" thick white translucent acrylic. No visible hot spots. Icons are face illuminated. Match colors as noted.

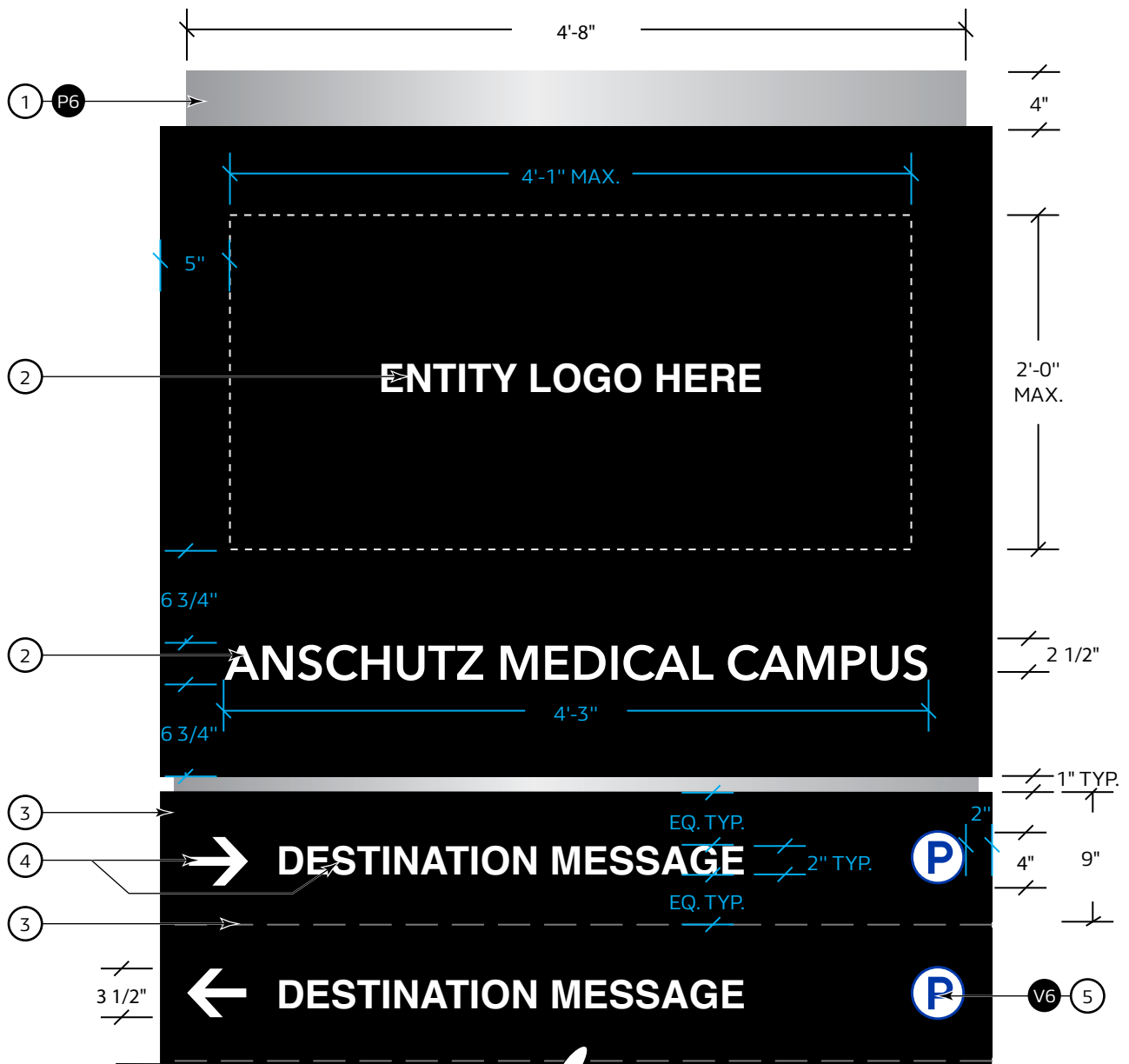

① Sign Type B.1: Single-Entity Directional - Detail View
 - Scale: 1" = 1' - 0"

B.1 Sign Type B.1: Single-Entity Directional

- 1 1" tall, 1" deep reveal to be painted to match as noted.



- 1 **Sign Type B.1: Illuminated Intent -Isometric View**
- Scale: NTS

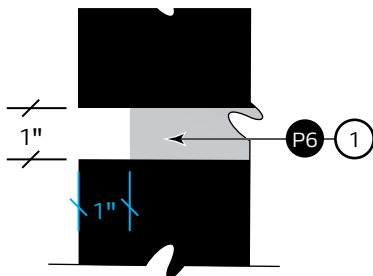

- 2 **Sign Type B.1: Reveal Detail View**
- Scale: 3" = 1' - 0"

B.1 Sign Type B.1: Single-Entity Directional

- ① Each sign to be painted to match the main brand color of the entity it is representing.
- ② Logo and text is 1/2" thick white acrylic push-through.

Note: All wayfinding messaging shown below are placeholder text and each entity is responsible for providing accurate messaging.

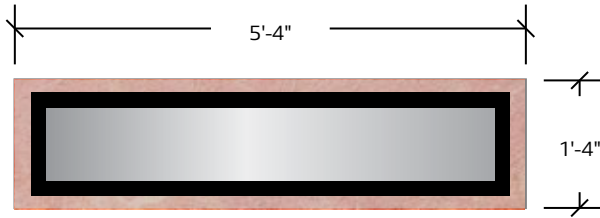

① Sign Type B.1: Single-Entity Directional - CU Anschutz - Plan View
- Scale: 1/2" = 1' - 0"

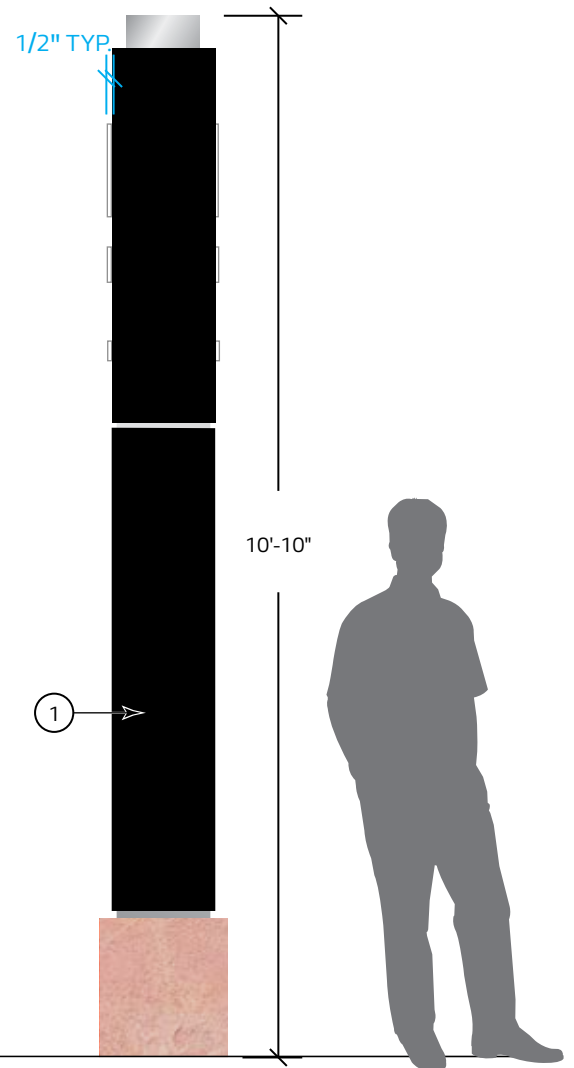
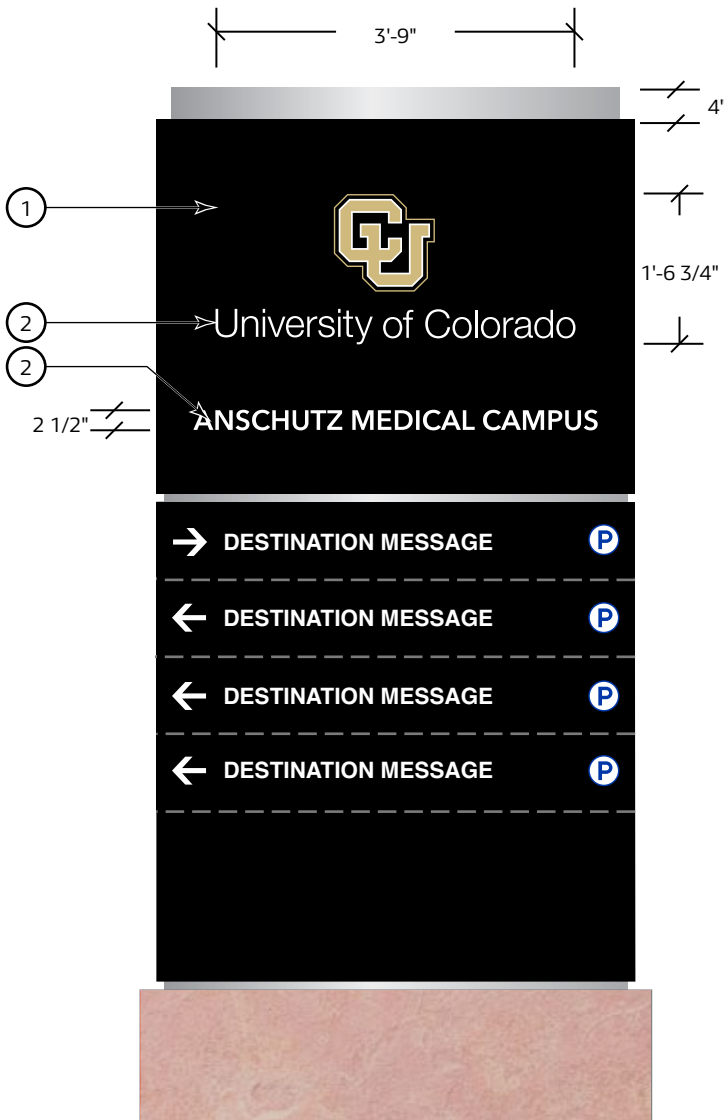

② Sign Type B.1: Single-Entity Directional - CU Anschutz
- Scale: 1/2" = 1' - 0"

③ Sign Type B.1: Single-Entity Directional - Side View
- Scale: 1/2" = 1' - 0"

PAGES 27 - 41 NOT APPLICABLE.

F Sign Type F: Map/Directory Kiosk

- ① Pre-cast concrete base. Footing as required by engineering. Footing not to be visible above grade.
- ② 1/8" thick brake-formed internally-illuminated aluminum cabinet with internal framing as required. Painted to match as noted.

- ③ 1/4" thick aluminum tubes with all visible surfaces painted to match as noted. All hardware to be concealed.
- ④ 1" tall, 1" deep reveal to be painted to match as noted.

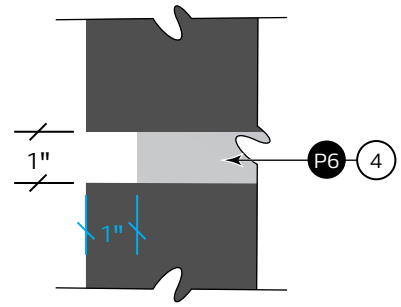
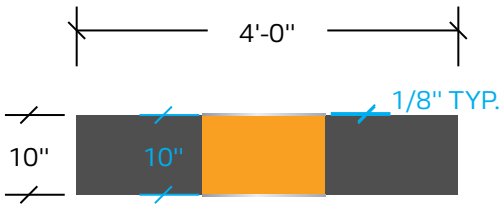

① Sign Type F: Map/Directory Kiosk - Plan View
- Scale: 1/2" = 1' - 0"

② Sign Type F: Reveal Detail View
- Scale: 3" = 1' - 0"

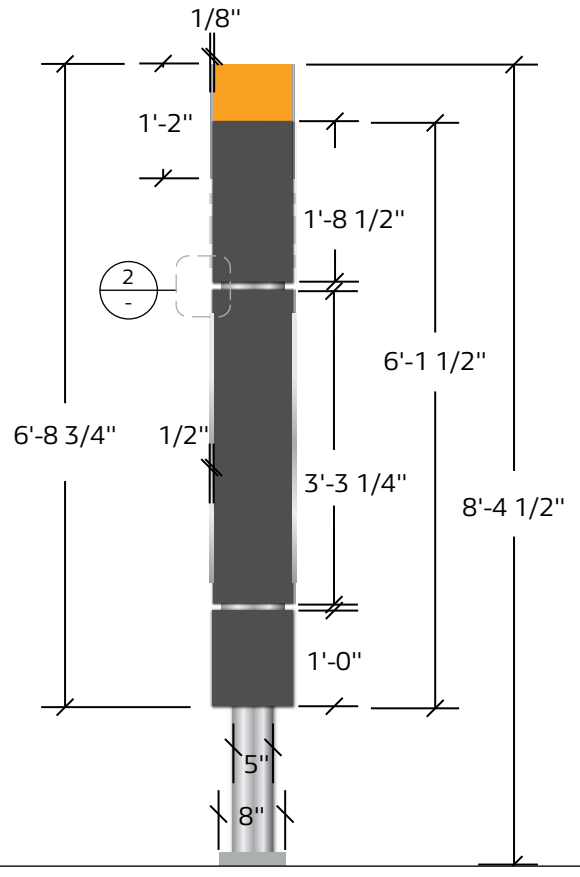
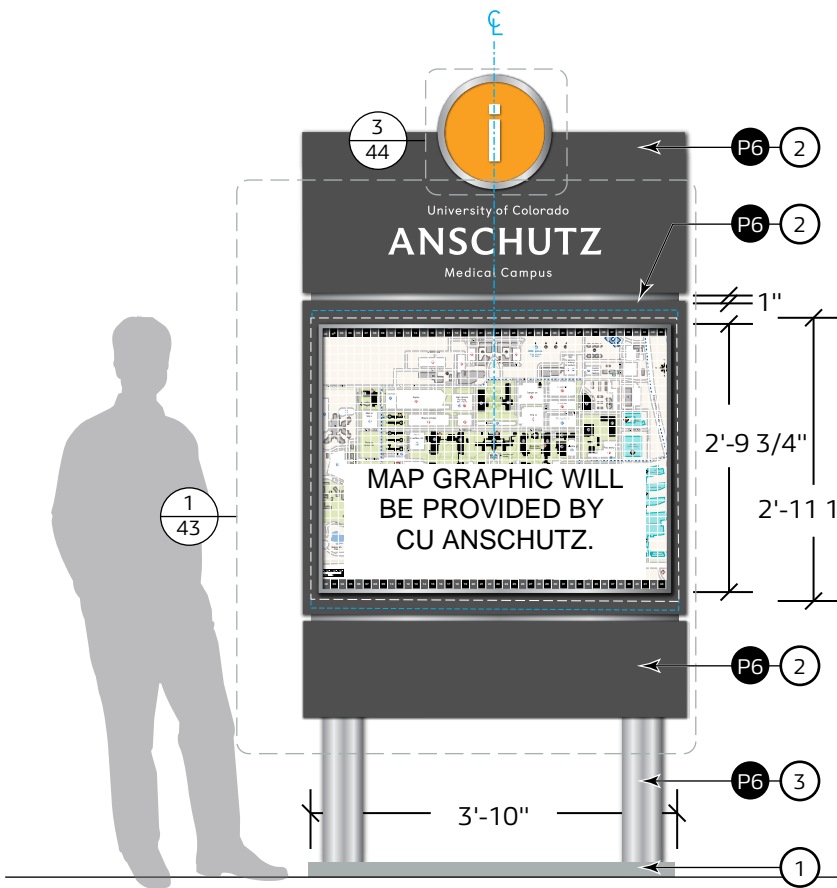

③ Sign Type F: Map/Directory Kiosk
- Scale: 1/2" = 1' - 0"

④ Sign Type F: Map/Directory Kiosk - Side View
- Scale: 1/2" = 1' - 0"

F Sign Type F: Map/Directory Kiosk

- ① 1/2" thick aluminum frame to be painted to match as noted. Frame to hold 1/4" thick, clear, non-glare acrylic window reveal and 1/8" thick, clear acrylic panel. Map art is UV resistant, high-resolution direct print on 2nd surface. Internally illuminated with no visible hot spots. Map panel to slide into track system in interior of cabinet to allow for changeability.
- ② Hinged door access panel (as noted by dashed white line) for maintenance and internal access to illumination elements and changeable map panel. Door attached with concealed, tamper proof mechanical fasteners and painted to match colors as noted.
- ③ Track system to be installed at top and bottom of hinged access door (as noted by dashed blue lines) and securely holds clear, non-glare acrylic map panel in place to show through window reveal. Track system to be integrated into hinged door access panel and must allow for changeability for future map updates.
- ④ Logo and text to be 1/2" thick white acrylic push-through.

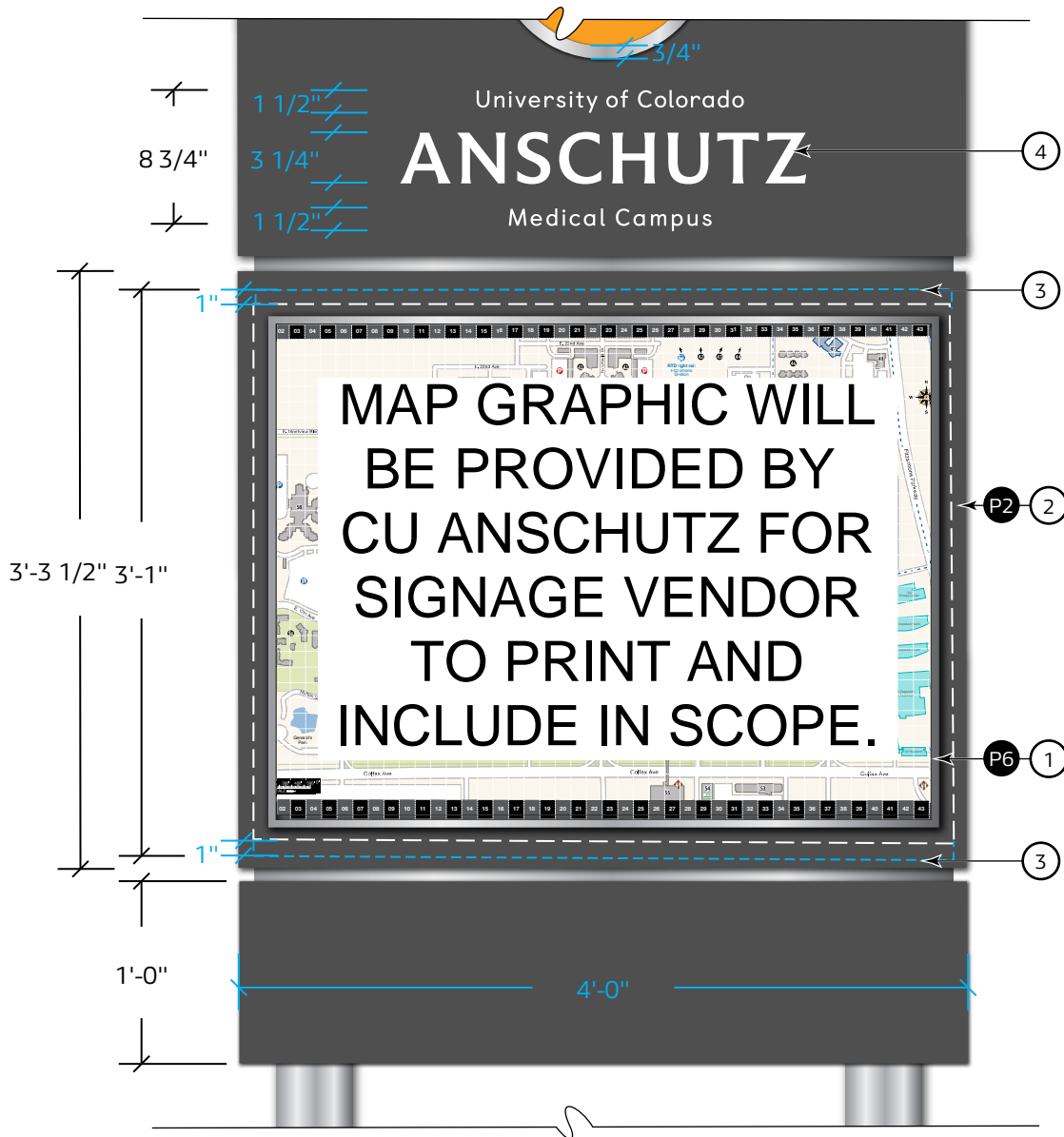

① Sign Type F: Map/Directory Kiosk - Detail
 - Scale: 1" = 1' - 0"

F Sign Type F: Map/Directory Kiosk

- ① 1/8" thick aluminum frame painted to match as noted and mechanically fastened to top of sign cabinet.

- ② Cut to shape vinyl to match color as noted. Seal with satin clear coat as required.
- ③ .25" white translucent acrylic panel to be internally illuminated.



① Sign Type F: Map/Directory Kiosk - Isometric Illuminated Intent - Detail
- Scale: NTS

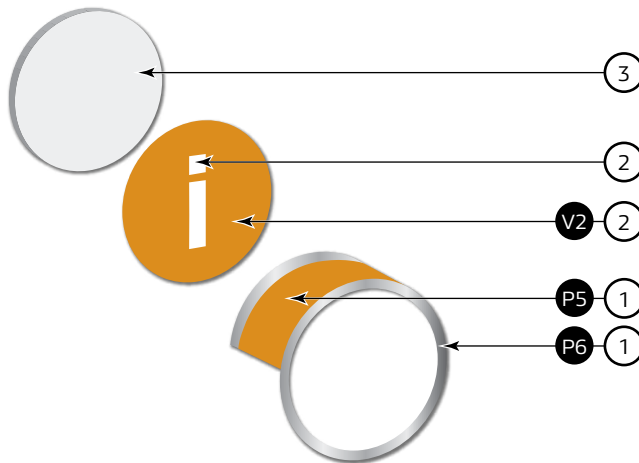

② Sign Type F: Map/Directory Kiosk - Exploded Detail View
- Scale: NTS

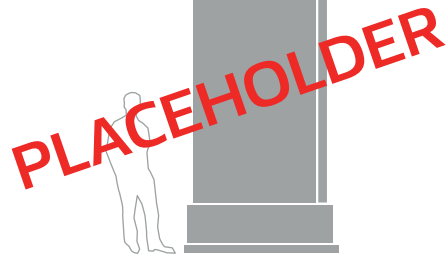

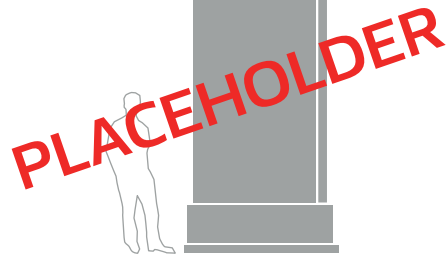

Location Plan

Request Access to signage locations at:

Ben Bohmann

Project Manager

Facilities Management

University of Colorado Denver

Anschutz Medical Campus

E: ben.bohmann@cuanschutz.edu

O: 303.724.3956

Approval Process

Each entity is held to equal design standards for CU Anschutz brand consistency.

All Entities shall:

[REDACTED]

Each submittal shall be in shop drawing format and drawn to scale at 1/2" = 1'-0" minimum.

Shop drawings shall include sign type, sign dimensions, colored elevations, photographs of existing signs of the same design (if applicable), sign sections and details, materials, colors, method(s) of illumination, and structural details.

Upon [REDACTED] request [REDACTED] provide drawings stamped and signed by a structural engineer registered in the State of Colorado.

New signage designs shall be reviewed [REDACTED] based upon the following criteria:

- Conformity to the CU Anschutz Medical Campus Signage Standards.
- Approximate designated sign locations
- Allowable types of sign construction
- Illumination Indication of all sign types and locations.

[REDACTED]

[REDACTED]

[REDACTED]

[REDACTED]

[REDACTED]
[REDACTED]

[REDACTED]
[REDACTED]

[REDACTED]
[REDACTED]
[REDACTED]

[REDACTED]
[REDACTED]
[REDACTED]

[REDACTED]
[REDACTED]

[REDACTED]
[REDACTED]

[REDACTED]
[REDACTED]

PLACEHOLD

[REDACTED]
[REDACTED]

[REDACTED]
[REDACTED]

[REDACTED]
[REDACTED]
[REDACTED]

[REDACTED]
[REDACTED]

[REDACTED]
[REDACTED]

This document was last revised
August 6th 2020

SECTION 01 78 23

OPERATION AND MAINTENANCE DATA

PART 1 - GENERAL

1.1 RELATED DOCUMENTS

- A. Drawings and general provisions of the Contract, including General and Supplementary Conditions and other Division 01 Specification Sections, apply to this Section.

1.2 SUMMARY

- A. Section includes administrative and procedural requirements for preparing operation and maintenance manuals, including the following:
 - 1. Operation and maintenance documentation directory.
 - 2. Systems, subsystems, and equipment operation and maintenance manuals.
 - 3. Product maintenance manuals.
 - 4. Emergency manuals.
 - 5. Framed operating and maintenance instructions.
- B. Related Requirements:
 - 1. Section 01 33 00 "Submittal Procedures" for submitting copies of submittals for operation and maintenance manuals.
 - 2. Section 01 91 13 "General Commissioning Requirements" for verification and compilation of data into operation and maintenance manuals.

1.3 DEFINITIONS

- A. System: An organized collection of parts, equipment, or subsystems united by regular interaction.
- B. Subsystem: A portion of a system with characteristics similar to a system.

1.4 CLOSEOUT SUBMITTALS

- A. Schedule: Submit each manual in final form prior to requesting inspection for Substantial Completion and at least 30 calendar days before commencing demonstration and training. Architect/Engineer will return copy with comments.
 - 1. Correct or revise each manual to comply with Architect/Engineer's comments. Submit copies of each corrected manual within 15 calendar days of receipt of Architect/Engineer's comments and prior to commencing demonstration and training.
- B. Format: Submit operations and maintenance manuals in the following format:
 - 1. PDF electronic file. Assemble each manual into a composite electronically indexed file. Submit on digital media acceptable to Architect/Engineer.

- a. Name each indexed document file in composite electronic index with applicable item name. Include a complete electronically linked operation and maintenance directory.
 - b. Compile entirely from documents with searchable text.
 - c. Enable inserted reviewer comments on draft submittals.
2. Paper copies. Assemble in accordance with the requirements of this Section.
- a. Submit three final copies, one to be retained by the Architect/Engineer and two to be retained by the University.
- C. Final Manual Submittal: Submit each manual in final form prior to requesting inspection for Substantial Completion and at least 30 calendar days before commencing demonstration and training. Architect/Engineer will return copy with comments.
1. Correct or revise each manual to comply with Architect/Engineer's comments. Submit copies of each corrected manual within 15 calendar days of receipt of Architect/Engineer's comments and prior to commencing demonstration and training.

PART 2 - PRODUCTS

2.1 OPERATION AND MAINTENANCE DOCUMENTATION DIRECTORY

- A. Directory: Prepare a single, comprehensive directory of emergency, operation, and maintenance data and materials, listing items and their location to facilitate ready access to desired information. Include a section in the directory for each of the following:
1. List of documents.
 2. List of systems.
 3. List of equipment.
 4. Table of contents.
- B. List of Systems and Subsystems: List systems alphabetically. Include references to operation and maintenance manuals that contain information about each system.
- C. List of Equipment: List equipment for each system, organized alphabetically by system. For pieces of equipment not part of system, list alphabetically in separate list.
- D. Tables of Contents: Include a table of contents for each emergency, operation, and maintenance manual.
- E. Identification: In the documentation directory and in each operation and maintenance manual, identify each system, subsystem, and piece of equipment with same designation used in the Contract Documents. If no designation exists, assign a designation according to ASHRAE Guideline 4, "Preparation of Operating and Maintenance Documentation for Building Systems."

2.2 GENERAL REQUIREMENTS FOR EMERGENCY, OPERATION, AND MAINTENANCE MANUALS

- A. Intent: Prepare data in form of an instructional manual for use by University personnel.
- B. Organization: Unless otherwise indicated, organize each manual into a separate section for each system and subsystem, and a separate section for each piece of equipment not part of a system. Each manual shall contain the following materials, in the order listed:

1. Title page.
 2. Table of contents.
 3. Manual contents.
- C. Title Page: Include the following information:
1. Subject matter included in manual.
 2. Name and address of Project.
 3. Name and address of University.
 4. Date of submittal.
 5. Name and contact information for Contractor.
 6. Name and contact information for Construction Manager.
 7. Name and contact information for Architect/Engineer.
 8. Name and contact information for Commissioning Authority.
 9. Names and contact information for major consultants to the Architect/Engineer that designed the systems contained in the manuals.
 10. Cross-reference to related systems in other operation and maintenance manuals.
- D. Table of Contents: List each product included in manual, identified by product name, indexed to the content of the volume, and cross-referenced to Specification Section number in Project Manual.
1. If operation or maintenance documentation requires more than one volume to accommodate data, include comprehensive table of contents for all volumes in each volume of the set.
- E. Manual Contents: Organize into sets of manageable size. Arrange contents alphabetically by system, subsystem, and equipment. If possible, assemble instructions for subsystems, equipment, and components of one system into a single binder.
- F. Manufacturers' Data: Where manuals contain manufacturers' standard printed data, include only sheets pertinent to product or component installed. Mark each sheet to identify each product or component incorporated into the Work. If data include more than one item in a tabular format, identify each item using appropriate references from the Contract Documents. Identify data applicable to the Work and delete references to information not applicable.
1. Prepare supplementary text if manufacturers' standard printed data are not available and where the information is necessary for proper operation and maintenance of equipment or systems.
- G. Drawings: Prepare drawings supplementing manufacturers' printed data to illustrate the relationship of component parts of equipment and systems and to illustrate control sequence and flow diagrams. Coordinate these drawings with information contained in record Drawings to ensure correct illustration of completed installation.
- H. Manuals, Electronic Files: Submit manuals in the form of a multiple file composite electronic PDF file for each manual type required.
1. Electronic Files: Use electronic files prepared by manufacturer where available. Where scanning of paper documents is required, configure scanned file for minimum readable file size and enable OCR (optical character recognition) to provide searchable text.
 2. File Names and Bookmarks: Enable bookmarking of individual documents based on file names. Name document files to correspond to system, subsystem, and equipment names used in manual directory and table of contents. Group documents for each system and subsystem into individual composite bookmarked files, then create composite manual, so that resulting bookmarks reflect the system, subsystem, and equipment names in a readily navigated file tree. Configure electronic manual to display bookmark panel on opening file.

- I. Manuals, Paper Copy: Submit manuals in the form of hard copy, bound and labeled volumes.
 1. Binders: Heavy-duty, three-ring, vinyl-covered, loose-leaf binders, in minimum 1 inch and maximum 2 inch thickness necessary to accommodate contents, sized to hold 8-1/2-by-11-inch paper; with clear plastic sleeve on spine to hold label describing contents and with pockets inside covers to hold folded oversize sheets.
 - a. If two or more binders are necessary to accommodate data of a system, organize data in each binder into groupings by subsystem and related components. Cross-reference other binders if necessary to provide essential information for proper operation or maintenance of equipment or system.
 - b. Identify each binder on front and spine, with printed title "OPERATION AND MAINTENANCE MANUAL," Project title or name, and subject matter of contents, and indicate Specification Section number on bottom of spine. Indicate volume number for multiple-volume sets.
 2. Dividers: Heavy-paper dividers with plastic-covered tabs for each section of the manual. Mark each tab to indicate contents. Include typed list of products and major components of equipment included in the section on each divider, cross-referenced to Specification Section number and title of Project Manual.
 3. Protective Plastic Sleeves: Transparent plastic sleeves designed to enclose diagnostic software storage media for computerized electronic equipment.
 4. Supplementary Text: Prepared on 8-1/2-by-11-inch, 20 lb., white bond paper.
 5. Drawings: Attach reinforced, punched binder tabs on drawings and bind with text.
 - a. If oversize drawings are necessary, fold drawings to same size as text pages and use as foldouts.
 - b. If drawings are too large to be used as foldouts, fold and place drawings in labeled envelopes and bind envelopes in rear of manual. At appropriate locations in manual, insert typewritten pages indicating drawing titles, descriptions of contents, and drawing locations.

2.3 SYSTEMS, SUBSYSTEMS AND EQUIPMENT OPERATION AND MAINTENANCE MANUALS

- A. General: Provide operation and maintenance manuals where indicated in individual Specification Section and the following:
 1. Heating, ventilating and air-conditioning equipment and systems.
 2. Plumbing equipment and systems.
 3. Special piping equipment and systems.
 4. Electrical distribution systems.
 5. Standby generator systems.
 6. Communications systems.
 7. Fire alarm and detection systems.
 8. Underground sprinkler systems.
 9. Automatic entrances.
 10. Food service equipment.
 11. Elevators.
 12. Other special construction and conveying systems.
- B. Operation Content: In addition to requirements in this Section, include operation data required in individual Specification Sections.
 1. Additional Operation Content Required:

- a. System, subsystem, and equipment descriptions. Use designations for systems and equipment indicated on Contract Documents.
 - b. Performance and design criteria if Contractor has delegated design responsibility.
 - c. Operating standards.
 - d. Operating procedures.
 - e. Operating logs.
 - f. Wiring diagrams.
 - g. Control diagrams.
 - h. Piped system diagrams.
 - i. Precautions against improper use.
 - j. License requirements including inspection and renewal dates.
2. Descriptions: Include the following:
 - a. Product name and model number. Use designations for products indicated on Contract Documents.
 - b. Manufacturer's name.
 - c. Equipment identification with serial number of each component.
 - d. Equipment function.
 - e. Operating characteristics.
 - f. Limiting conditions.
 - g. Performance curves.
 - h. Engineering data and tests.
 - i. Complete nomenclature and number of replacement parts.
 3. Operating Procedures: Include the following, as applicable:
 - a. Startup procedures.
 - b. Equipment or system break-in procedures.
 - c. Routine and normal operating instructions.
 - d. Regulation and control procedures.
 - e. Instructions on stopping.
 - f. Normal shutdown instructions.
 - g. Seasonal and weekend operating instructions.
 - h. Required sequences for electric or electronic systems.
 - i. Special operating instructions and procedures.
 4. Systems and Equipment Controls: Describe the sequence of operation, and diagram controls as installed.
 5. Piped Systems: Diagram piping as installed, and identify color-coding where required for identification.
- C. Maintenance Content: For each system, subsystem, and piece of equipment not part of a system, include source information, manufacturers' maintenance documentation, maintenance procedures, maintenance and service schedules, spare parts list and source information, maintenance service contracts, and warranty and bond information, as described below.
1. Source Information: Provide the following information in a list for each product included in manual:
 - a. Name, address, and telephone number of Installer or supplier and maintenance service agent.
 - b. Name, address, and telephone number of local source for supply of replacement parts.
 - c. Name, address, and telephone number of maintenance contractor, where appropriate.
 - d. Cross-reference Specification Section number and title.
 - e. Drawing or schedule designation or identifier where applicable.

2. **Manufacturers' Maintenance Documentation:** Manufacturers' maintenance documentation including the following information for each component part or piece of equipment:
 - a. Standard maintenance instructions and bulletins.
 - b. Drawings, diagrams, and instructions required for maintenance, including disassembly and component removal, replacement, and assembly.
 - c. Identification and nomenclature of parts and components.
 - d. List of items recommended to be stocked as spare parts.
3. **Maintenance Procedures:** Include the following information and items that detail essential maintenance procedures:
 - a. Test and inspection instructions.
 - b. Troubleshooting guide.
 - c. Precautions against improper maintenance.
 - d. Disassembly; component removal, repair, and replacement; and reassembly instructions.
 - e. Aligning, adjusting, and checking instructions.
 - f. Demonstration and training video recording, if available.
4. **Maintenance and Service Schedules:** Include service and lubrication requirements, list of required lubricants for equipment, and separate schedules for preventive and routine maintenance and service with standard time allotment.
 - a. **Scheduled Maintenance and Service:** Tabulate actions for daily, weekly, monthly, quarterly, semiannual, and annual frequencies.
 - b. **Maintenance and Service Record:** Include manufacturers' forms for recording maintenance.
5. **Spare Parts List and Source Information:** Include lists of replacement and repair parts, with parts identified and cross-referenced to manufacturers' maintenance documentation and local sources of maintenance materials and related services.
6. **Maintenance Service Contracts:** Include copies of maintenance agreements with name and telephone number of service agent.
7. **Warranties and Bonds:** Include copies of warranties and bonds and lists of circumstances and conditions that would affect validity of warranties or bonds.
 - a. Include procedures to follow and required notifications for warranty claims.
 - b. Include information sheet covering proper procedures in event of failure and instances which might affect validity of warranties and bonds.

2.4 PRODUCT MAINTENANCE MANUALS

- A. **Content:** Organize manual into a separate section for each product, material, and finish. Separate into two manuals: one for exterior moisture protection products and those exposed to weather and one for interior products. Include source information, product information, maintenance procedures, repair materials and sources, and warranties and bonds, as described below.
- B. **Source Information:** Provide the following information for each product included in manual:
 1. Name, address, and telephone number of Installer or supplier and maintenance service agent.
 2. Cross-reference Specification Section number and title.
 3. Drawing or schedule designation or identifier where applicable.
- C. **Product Information:** Include the following, as applicable:

1. Product name and model number.
2. Manufacturer's name.
3. Color, pattern, and texture.
4. Material and chemical composition.
5. Reordering information for specially manufactured products.

D. Maintenance Procedures: Include manufacturer's written recommendations and the following:

1. Inspection procedures.
2. Types of cleaning agents to be used and methods of cleaning.
3. List of cleaning agents and methods of cleaning detrimental to product.
4. Schedule for routine cleaning and maintenance.
5. Repair instructions.

E. Repair Materials and Sources: Include lists of materials and local sources of materials and related services.

F. Warranties and Bonds: Include copies of warranties and bonds and lists of circumstances and conditions that would affect validity of warranties or bonds.

1. Include procedures to follow and required notifications for warranty claims.

2.5 EMERGENCY MANUALS

A. Content: Organize manual into a separate section for each of the following:

1. Type of emergency.
2. Emergency instructions.
3. Emergency procedures.

B. Type of Emergency: Where applicable for each type of emergency indicated below, include instructions and procedures for each system, subsystem, piece of equipment, and component:

1. Fire.
2. Flood.
3. Gas leak.
4. Water leak.
5. Power failure.
6. Water outage.
7. System, subsystem, or equipment failure.
8. Chemical release or spill.

C. Emergency Instructions: Describe and explain warnings, trouble indications, error messages, and similar codes and signals. Include responsibilities of University's operating personnel for notification of Installer, supplier, and manufacturer to maintain warranties.

D. Emergency Procedures: Include the following, as applicable:

1. Instructions on stopping.
2. Shutdown instructions for each type of emergency.
3. Operating instructions for conditions outside normal operating limits.
4. Required sequences for electric or electronic systems.
5. Special operating instructions and procedures.

2.6 FRAMED OPERATING AND MAINENANCE INSTRUCTIONS

- A. All mechanically and electrically operated equipment and controls shall be provided with legible and complete wiring diagrams, schematics, operating instructions, and pertinent preventative maintenance instructions in a sturdy frame with clear glass or plastic cover. Use non-fading, permanent media.
- B. Locate frames in the same room or service enclosure as equipment, or in the nearest mechanical or electrical room.

PART 3 - EXECUTION (Not Used)

END OF SECTION 01 78 23

parking will be provided on the approval of the Parking Office. Gated lots will require the vehicle owner to receive a University ID badge and pay a badge fee (\$14). The University does not provide any free parking or badges.

- g. No work is to be conducted from the Montview Boulevard roadway unless the contractor secures their road closures permit from the City of Aurora. The University is not involved with nor controls Montview Blvd traffic closure requests, associated costs for closure requests, City of Aurora requirements, or securing of said permits. This permit cost would be the GC's responsibility to cover. It is highly recommended that contractors conduct signage installs along Montview Blvd from University property and not the roadway.

END OF ADDENDUM 3 NARRATIVE, ATTACHMENTS FOLLOW.



STATE OF COLORADO
OFFICE OF THE STATE ARCHITECT
STATE BUILDINGS PROGRAMS

BID

Institution/Agency: University of Colorado Anschutz Medical Campus

Project No./Name: 19-182047 / CU Anschutz Campus-Wide Wayfinding Signs

Bidder Acknowledges Receipt of Addenda Numbers: →	No <input type="checkbox"/>	Yes <input type="checkbox"/>	If Yes see 3A below
Bidder Anticipates Services outside the United States or Colorado:*	Yes <input type="checkbox"/>	No <input type="checkbox"/>	If No see 3B below
Bidder will comply with 80% Colorado Labor on project above \$500,000:	No <input type="checkbox"/>	Yes <input type="checkbox"/>	If Yes see 3C below
Bidder is a Service-Disabled Veteran Owned Small Business:*			

Base Bid

\$ _____

(Refer to Bid Alternate Form SC-6.13.1 Attached, If Applicable)

Bidder's Time of Completion Must match project schedule (Addendum #2)

- a. Time Period from Notice to Proceed to Substantial Completion: _____
- b. Time Period from Substantial Completion to Final Acceptance: _____
- c. Total Time of Completion of Entire Project (a + b): _____

1. **BID:** Pursuant to the advertisement by the State of Colorado dated _____ the undersigned bidder hereby proposes to furnish all the labor and materials and to perform all the work required for the complete and prompt execution of everything described or shown in or reasonably implied from the Bidding Documents, including the Drawings and Specifications, for the work and for the base bid indicated above. Bidders should include all taxes that are applicable.
2. **EXAMINATION OF DOCUMENTS AND SITE:** The bidder has carefully examined the Bidding Documents, including the Drawings and Specifications, and has examined the site of the Work, so as to make certain of the conditions at the site and to gain a clear understanding of the work to be done.
3. **PARTIES INTERESTED IN BID:** The bidder hereby certifies that the only persons or parties interested in this Bid are those named herein, and that no other bidder or prospective bidder has given any information concerning this Bid.
 - A. If the bidder anticipates services under the contract or any subcontracts will be performed outside the United States or Colorado, the bidder shall provide in a written statement which must include, but need not be limited to the type of services that will be performed at a location outside the United States or Colorado and the reason why it is necessary or advantageous to go outside the United States or Colorado to perform such services. (Does not apply to any project that receives federal moneys) *
 - B. For State Public Works projects per C.R.S. 8-17-101, Colorado labor shall be employed to perform at least 80% of the work. Colorado Labor means any person who is a resident of the state of Colorado at the time of the Public Works project. Bidders indicating that their bid proposal will not comply with the 80% Colorado Labor requirement are required to submit written justification along with the bid submission. (Does not apply to any project that receives federal moneys) *
 - C. A Service-Disabled Veteran Owned Small Business (SDVOSB) per C.R.S. 24-103-211, means a business that is incorporated or organized in Colorado or maintains a place of business or has an office in Colorado and is officially registered and verified by the Center for Veteran Enterprise within the U.S. Department of Veteran Affairs. Attach proof of certification along with the bid submission. *
4. **BID GUARANTEE:** This Bid is accompanied by the required Bid Guarantee. You are authorized to hold said Bid Guarantee for a period of not more than thirty (30) days after the opening of the Bids for the work above indicated, unless the undersigned bidder is awarded the Contract, within said period, in which event the Director, State Buildings Programs, may retain said Bid Guarantee, until the undersigned bidder has executed the required Agreement and furnished the required Performance Bond, Labor and Material Payment Bond, Insurance Policy and Certificates of Insurance and Affidavit Regarding Unauthorized Immigrants.
5. **TIME OF COMPLETION:** The bidder agrees to achieve Substantial Completion of the Project from the date of the Notice to Proceed within the number of calendar days entered above, and in addition, further agrees that the period between Substantial Completion and Final Acceptance of the Project will not exceed the number of

calendar days noted above. If awarded the Work, the bidder agrees to begin performance within ten (10) days from the date of the Notice to Proceed subject to Article 46, Time of Completion and Liquidated Damages of the General Conditions of the Contract, and agrees to prosecute the Work with due diligence to completion. The bidder represents that Article 7D of the Contractor's Agreement (SC-6.21) has been reviewed to determine the type and amount of any liquidated damages that may be specified for this contract.

- 6. **EXECUTION OF DOCUMENTS:** The bidder understands that if this Bid is accepted, bidder must execute the required Agreement and furnish the required Performance Bond, Labor and Material Payment Bond, Insurance Policy and Certificates of Insurance and Affidavit Regarding Unauthorized Immigrants within ten (10) days from the date of the Notice of Award, and that the bidder will be required to sign to acknowledge and accept the Contract Documents, including the Drawings and Specifications.
- 7. **ALTERNATES:** Refer to the Information for Bidders (SC-6.12) for Method of Award for Alternates and use State Form SBP-6.13.1 Bid Alternates form to be submitted with this bid form if alternates are requested by the institution/agency in the solicitation documents.
- 8. **Submit wage rates** (direct labor costs) for prime contractor and subcontractor as requested by the institution/agency in the solicitation documents.
- 9. **The right is reserved to waive informalities and to reject any and all Bids.**

**Does not apply to projects for Institutions of Higher Education that have opted out of the State Procurement Code.*

SIGNATURES: If the Bid is being submitted by a Corporation, the Bid shall be signed by an officer, i.e., President or Vice-President. If a sole proprietorship or a partnership is submitting the Bid, the Bid shall so indicate and be properly signed.

Dated this _____ Day of _____, 20_____

THE BIDDER:

Company Name

Address (including city, state and zip)

Phone number:

Name (Print) and Title

Signature

Signage Vendor Name/Address: _____

Signage Vendor fabrication facility location(s): _____

Verified Signage Installers are employees (not subcontractors) of signage vendor: _____

Concrete Subcontractor: _____

Masonry Subcontractor: _____

Electrical Subcontractor: _____

UNIT PRICES:

Type B Sign Unit price from signage vendor: \$ _____

Type B Sign Unit price fully installed (All trades excluding underground electrical): \$ _____

Type B1 Sign Unit price form signage vendor: \$ _____

Type B1 Sign Unit price fully installed (All trades excluding underground electrical): \$ _____

Type F Sign Unit price form signage vendor: \$ _____

Type F Sign Unit price fully installed (All trades excluding underground electrical): \$ _____