

SECTION 02 81 00 - TRANSPORTATION/DISPOSAL OF HAZARDOUS MATERIAL

PART 1 - GENERAL

1.1 SUMMARY

- A. This section provides standards discovery, abatement, disposal, and worker protection for all hazardous materials including asbestos, lead, polychlorinated biphenyls (PCBs), mercury, radioactive materials, and mold.
- B. All hazardous materials and waste must be managed and coordinated with Environmental Health and Safety (EHS) through the University Project Manager.

1.2 REFERENCES

- A. Occupational Safety and Health Administration, 29 CFR 1926.1101, Asbestos.
- B. Occupational Safety and Health Administration, 29 CFR 1926.62, Lead Standard.
- C. Environmental Protection Agency, 40 CFR 763.120, Asbestos Worker Protection Rule.
- D. Environmental Protection Agency, 40 CFR 61, National Emissions Standards for Hazardous Air Pollutants.
- E. Environmental Protection Agency 40 CFR 261.24, Toxicity Characteristic
- F. Environmental Protection Agency, 40 CFR 262, Standards Applicable to Generators of Hazardous Waste
- G. Environmental Protection Agency, 40 CFR 265, Interim Status Standards for Owners and Operators of Hazardous Waste Treatment Storage and Disposal Facilities.
- H. Code of Colorado Regulation Number 8 Control of Hazardous Air Pollutants, Part B Asbestos Control, 5 CCR 1001 – 10 Part B.
- I. Colorado Department of Public Health and Environment (CDPHE) Regulations Pertaining to Solid Waste Sites and Facilities, Section 5.5. Management of Asbestos-Contaminated Soil, 6 CCR 1007-2.
- J. Air Quality Control Commission (AQCC) Regulations 19 – Lead-Based Paint Abatement.
- K. Asbestos-Contaminated Soil Management, Standard Operating Procedure Document, Version 1, February 26, 2010.

1.3 SYSTEM PERFORMANCE REQUIREMENTS

- A. Performance Requirements - Asbestos
 - 1. Presence on Campus:
 - a. Asbestos is present in many building in and around the campus. Typical forms of asbestos containing materials (ACM) include pipe insulation, ceiling, wall, floor and roof materials.
 - b. Investigate every project where work will occur prior to soil disturbing activities to identify asbestos containing materials (ACM). The University Project Manager is responsible for coordinating and ensuring that an inspection or review of previous surveys and any required sampling be performed prior to finalizing the scope or work and associated budget.

- c. Include the cost of investigations, sampling, waste transportation, disposal and associated costs in the cost of the project.
 2. Excavation Notifications: Required as described below prior to beginning soil disturbing activities.
 - a. Localized Limited Quantity Shallow Hand Digging – No notification required.
 - b. Small Scale Localized Hand/Equipment Excavation – No notification required.
 - c. Moderate Scale Localized Equipment Excavation – Notification to the University.
 - d. Large Scale Equipment Excavation – Notification to the University.
 3. Discovery of Asbestos:
 - a. Notify contractors and the University Project Manager via project documents to stop work when asbestos is encountered or thought to be encountered. It is the responsibility of the University Project Manager to decide what type of action will follow, in consultation with the University's EHS Department.
 4. Asbestos Removal:
 - a. Perform any asbestos removal (abatement), repair, encapsulation or spill clean-up in accordance with the above referenced regulatory standards.
 - b. Utilize qualified and trained personnel for abatement design and removal in accordance with the above referenced regulatory standards.
 5. Asbestos Containing Waste
 - a. Follow the University asbestos waste disposal guidelines and Environmental Protection Agency regulations for disposal of asbestos generated at each project.
- B. Performance Requirements – Lead
 1. Presence on Campus:
 - a. Typical forms of lead containing materials (LCM) include paint, lead shielding materials, electronic equipment, and piping (sink traps).
 - b. Consult with EHS through the University Project Manager to determine when LCM investigation is required. The University Project Manager is responsible for coordinating and ensuring that an inspection or review of previous surveys and any required sampling be performed prior to finalizing the scope or work and associated budget.
 - c. Include the cost of investigations, sampling, waste transportation, disposal and associated costs in the cost of the project.
 2. Discovery of Lead:
 - a. Suspect LCM at all painted surfaces of older campus buildings, brick, and walls and floors in rooms designated (or previously designated) for radiography.
 - b. Notify contractors and the University Project Manager via project documents when lead is encountered or thought to be encountered. It is the responsibility of the University Project Manager to consult with EHS to decide what type of action will follow.
 3. Lead Renovation:
 - a. Perform any renovation of lead containing materials, repair, encapsulation or clean-up in accordance with the above referenced regulatory standards.
 - b. Utilize qualified and trained personnel for renovation in accordance with the above referenced regulatory standards.
 4. Handling of Lead Waste:
 - a. Coordinate with EHS through the University Project Manager.
 - b. Include all costs associated with handling of lead waste in the Project Cost.

1.4 SUBMITTALS

- A. Abatement Specifications:
 1. Provide a certified asbestos project manager on all asbestos abatement projects in which the amount of friable asbestos material to be abated exceeds 1000 linear feet on pipes or 3000 square feet on other surfaces.
 2. The certified asbestos project manager must prepare and approve written abatement specifications.
 3. Coordinate with the University EHS Department for additional requirements per project.

B. Asbestos Waste Manifests:

1. Prepare hazardous waste manifests for all asbestos waste shipments associated with University asbestos related projects. Submit copies and originals of these manifests in sequential (numerical) order to the University.

PART 2 - PRODUCTS (Not Applicable)

PART 3 - EXECUTION (Not Applicable)

PART 4 - ILLUSTRATIONS

A. Asbestos-Contaminated Soil Management, Standard Operating Procedure Document, Version 1, February 26, 2010.

1. Coordinate with the University Project Manager for attachments.

ASBESTOS-CONTAMINATED SOIL MANAGEMENT

STANDARD OPERATING PROCEDURE DOCUMENT

UNIVERSITY OF COLORADO DENVER ANSCHUTZ MEDICAL CAMPUS

Prepared for



University of Colorado Denver



February 26, 2010



WALSH ENVIRONMENTAL SCIENTISTS AND ENGINEERS, LLC

4888 Pearl East Circle, Suite 108

Boulder, Colorado 80301

(303) 443-3282

Project Number: 4299-630

**UNIVERSITY OF COLORADO DENVER
ANSCHUTZ MEDICAL CAMPUS (AMC)
ASBESTOS-CONTAMINATED SOIL MANAGEMENT
STANDARD OPERATING PROCEDURE DOCUMENT**

February 26, 2010

Prepared for: University of Colorado Denver
Anschutz Medical Campus

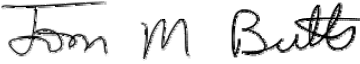
Prepared by: 

Tom Butts
State of Colorado Certified Asbestos Project Designer

Submitted by
WALSH ENVIRONMENTAL SCIENTISTS AND ENGINEERS, LLC
4888 Pearl East Circle, Suite 108
Boulder, Colorado 80301
(303) 443-3282

WALSH Project Number: 4299-630

DISTRIBUTION LIST

UCD

Christina Aguilera

Mike Barden

Dan Kerley

Ken Neeper

Colorado Department of Public Health and Environment

Jeff Swanson

Walsh Environmental

Steve Tarasar

Tom Butts

**University of Colorado
Anschutz Medical Campus
Asbestos-Contaminated Soil Management
Standard Operating Procedure Document**

Table of Contents

1	Purpose.....	1
2	Scope.....	1
3	Primary Contacts, Roles and Responsibilities	1
4	Definitions and Abbreviations	2
5	Disclosure due to Potential to Encounter ACS.....	3
6	Regulatory Summary and Regulatory References.....	4
7	Classification of Types of Soil Disturbing Activities.....	8
8	Excavation Notifications.....	9
9	Excavation Planning	10
10	Training Requirements.....	11
11	ACS Characterization Protocols and Trigger Levels.....	13
12	Limited Quantity ACS Management Procedures.....	15
13	Significant Quantity ACS Management Procedures where only Nonfriable Asbestos Material is Present.....	15
14	Significant Quantity ACS Management Procedures where Friable Asbestos Material is Present.....	20
15	Special Considerations.....	26
16	Project Reporting	28
17	SOP Review and Revision	29
18	Attachments	29

Attachments

Attachment #1	ACS Classification and AMC Boundary Site Drawing (and Survey Drawings)
Attachment #2	Historical Buildings and Steam Tunnels Site Drawing
Attachment #3	SOP Flow Chart
Attachment #4	Soil Sampling and Analysis Plan (SAP)
Attachment #5	Remediation Plan
Attachment #6	CDPHE Notification Summary and Notification Forms

1 Purpose

This Standard Operating Procedure (SOP) document provides written standard operating procedures that are the minimum requirements for the proper training, handling, packaging, and disposal of asbestos-contaminated soil (ACS) during soil disturbing activities at the Anschutz Medical Campus (AMC) of the University of Colorado Denver (UCD). This SOP document provides specific procedures for the “**management**” of asbestos contaminated soil to remove only that asbestos contaminated soil, necessary to perform the work. Where “**remediation**” is intended to remove the full extent and depth of asbestos contaminated soil for a specific area, refer to the attached *Soil Sampling and Analysis* procedures provided as a supplement to this SOP in Attachment #4 and *Remediation* procedures provided as a supplement to this SOP in Attachment #5 of this document. The SOP was prepared for CDPHE review and approval to allow AMC to use this SOP for management of the discovered ACS rather than preparing a site specific soil characterization and management plan (SCMP) each time ACS is discovered at ACM. This document is intended for use by those directly involved with soil disturbing activities on the campus, and those who provide management/supervision of these soil disturbing activities.

UCD AMC is part of the University of Colorado and is a 227-acre campus devoted to biomedical education, patient care, and drug development is located in Aurora, Colorado on the site of the former Fitzsimons Army Medical Center. The campus is located on the north side of Colfax Avenue, between Peoria Street and Fitzsimons Parkway.

2 Scope

The procedures provided in this document shall apply to all personnel and all activities involved with the disturbance of soil known to contain asbestos material or soil that may reasonably be considered to contain asbestos material.

3 Primary Contacts, Roles and Responsibilities

<i>Organization</i>	<i>Role/Responsibility</i>	<i>Contact Information</i>
UCD – Facilities Management	Project Management	Ken Neeper, Manager Infrastructure Development, Phone: 303.724.0249 Email: Ken.Neeper@UCDenver.edu
UCD – Environmental Health and Safety Division	Environmental Compliance – Health and Safety	Christina Aguilera Phone: 303.724.0242 Email: Christina.Aguilera@ucdenver.edu
CDPHE HMWMD	Regulatory Agency	Jeff Swanson – Remediation and Restoration Unit – Federal Facilities Program Phone: 303.692.3416 jrswanso@cdphe.state.co.us
Non-ACS Excavation Contractor	As needed excavation of non-ACS soil in accordance with this plan	To be determined as needed
ACS Excavation Contractor	As needed removal of ACS in accordance with this SOP	To be determined as needed
ACS Consultant	As needed ACS Consulting (soil characterization, remediation oversight, soil spotting, air monitoring)	To be determined as needed

4 Definitions and Abbreviations

4.1 Abbreviations

ACM	Asbestos-containing materials
ACS	Asbestos-contaminated soil
AMC	Anschutz Medical Campus
AMS	Asbestos Air Monitoring Specialist, CDPHE Certified
CDPHE	Colorado Department of Public Health and Environment
GIS	Geographic information system
GPS	Geographic positioning system
MPH	Miles per hour
NESHAP	National Emissions Standards for Hazardous Air Pollutants
NIOSH	National Institute of Occupational Safety and Health
OSHA	Occupational Safety and Health Administration
PCM	Phase Contract Microscope
PLM	Polarized Light Microscopy
PPE	Personal Protective Equipment
SOP	Standard Operating Procedure

4.2 Definitions

“**Air Monitoring Specialist**” means a person who performs air monitoring referred to in this guidance and who is certified to perform air monitoring in accordance with Air Regulation No. 8, Part B.

Asbestos Soil Inspector means a person certified in accordance with Air Regulation No. 8, Part B, to perform asbestos inspection and sampling, and who has a minimum of six (6) months experience in asbestos-contaminated soil inspections.

“**Asbestos Supervisor**” means a person who has been certified as an asbestos Supervisor in accordance with Air Regulation No. 8, Part B.

“**Asbestos Project Designer**” or “**Project Designer**” means a person who has been certified as an asbestos Project Designer in accordance with Air Regulation No. 8, Part B.

“**Adequately wet**” means sufficiently mix or penetrate with liquid to completely prevent the release of particulate material and fibers into the ambient air. If visible emissions are observed coming from asbestos-contaminated soil or asbestos-containing material, then the material has not been adequately wetted. However, the absence of visible emissions is not sufficient evidence of being adequately wet. Guidance on determining when a material is adequately wet can be found in EPA’s *Asbestos NESHAP Adequately Wet Guidance*, EPA 340/1-90-019 (December 1990).

“**Asbestos**” means the asbestiform varieties of serpentinite (chrysotile), riebeckite (crocidolite), amosite (cummingtonite-grunerite), anthophyllite, and actinolite-tremolite.

“**Asbestos-contaminated soil**” means soil containing any amount of asbestos.

“**Asbestos waste**” means any asbestos-containing material whether it contains friable or nonfriable asbestos, that is not intended for further use. This term includes but is not limited to asbestos mill tailings, asbestos from pollution control devices, and containers that contain asbestos.

“**Asbestos-containing material**” means any material that contains more than one percent (1%) asbestos by weight, area or volume.

“**Consultant**” refers to entity contracted to perform training, inspections, and air monitoring related to soil disturbing activities in accordance with the SOP.

“**Contractor**” refers to entity contracted to perform soil disturbing activities in accordance with the SOP.

“**Facility Component**” means any component associated with a structure, installation, or building and includes buried utilities, tanks, structures or other installations.

“**Friable**” means that the material, when dry, may be crumbled, pulverized, or reduced to powder by hand pressure, and includes previously nonfriable material after such previously nonfriable material becomes damaged to the extent that when dry it may be crumbled, pulverized, or reduced to powder by hand pressure.

“**Leak tight**” means that solids, liquids, or gases cannot escape or spill out. It also means dust tight.

“**Mechanical**” means operated or produced by mechanism or machine. This may include, but shall not be limited to, an excavator, backhoe, grader, tiller, auger, or hand shovel.

“**Nonfriable**” means material which, when dry, may not be crumbled, pulverized, or reduced to powder by hand pressure.

“**Remediation**” or “**Remediate**” means a cleanup or removal to prevent or minimize the possible current or future release of hazardous substances to prevent an unacceptable threat to present or future public health, welfare or the environment.

“**Site**” or “**solid waste disposal site**” means the location for a facility chosen based upon geologic, hydrogeologic and operational considerations. For the purpose of Section 5.5 of the Solid Waste Regulations “site” means the area or areas where soil-disturbing activities are occurring or will occur.

“**Soil-disturbing activities**” means excavation, grading, tilling, or any other mechanical activity used to disturb the soil.

“**Visible emissions**” means any emissions which are visually detectable without the aid of instruments, coming from material containing asbestos, asbestos waste, asbestos-contaminated soil, or from handling and disposal of asbestos waste, material containing asbestos or asbestos-contaminated soil.

“**Work Area**” means the area where soil disturbing activities are occurring. For asbestos contaminated soil disturbance, Work Area also means the regulated/controlled area boundary.

5 Disclosure due to Potential to Encounter ACS

The Anschutz Medical Campus (AMC) formerly the Fitzsimons Army Medical Center contained numerous buildings, some of which had been demolished and buried by the Army prior to property transfer to UCD. During development of the site by UCD, buried asbestos-containing materials located on building components (primarily direct buried steam lines, etc) and areas of asbestos-contaminated soil (asbestos debris in soil from prior building demolition, etc) have been discovered on the site. Based on excavation activities to date, these occurrences can be characterized as localized. Based on historical findings, the potential to encounter ACS on the AMC campus fall into one of the three following categories:

1. **Known ACS Area** - An area that is classified as having known ACS is one that has confirmed asbestos-containing material in the soil identified either from subsurface intrusive investigation, or from visual observation on the surface, in sidewalls, embankments, etc. This excavation is conducted by properly trained personnel in accordance with the provisions of this SOP.
2. **Moderate to High Potential ACS Area**– An area that is classified as having a **moderate potential** for encountering ACS is one based on historical review that asbestos material may be encountered in the soil *where non-suspect construction debris has been observed historically, including wood, concrete, brick and metal components*. An area that is classified as having a **high potential** for encountering ACS is one based on historical review that *suspect asbestos material is likely to be encountered in the soil where suspect asbestos construction debris has been observed historically*. Areas of Moderate to High Potential for encountering ACS may necessitate additional characterization using surface and subsurface visual inspection methods. For areas of Moderate to High Potential ACS, soil excavation activities shall be observed by an asbestos building inspector with 6 months asbestos in soil experience (asbestos soil inspector). For areas of Moderate to High Potential ACS “On-the-job” ACS awareness training shall be provided to workers directly involved with soil-disturbing activities.
3. **Low Potential ACS Area**– An area that is classified as having a low potential for encountering ACS is one in which historical review does not identify buildings or structures that previously existed at the site, utility corridors, other waste materials, or other indications that asbestos may exist on the site. A site classified as

having a low potential for encountering ACS would not be a “reason to believe that visible asbestos may be encountered.” Sites with a low potential for encountering ACS would not necessitate additional characterization, spotting, “on-the-job” awareness training, or other special provisions. However, if construction debris or potential ACM is encountered during the course of soil disturbance, then the area would become a moderate to high potential ACS area and will be subject to awareness training, soil spotting and other provisions as described in this SOP.

Asbestos debris in soil at AMC can consist of friable asbestos debris (pipe insulation, etc), nonfriable asbestos debris (floor tile and cement asbestos sheet used on roofs, etc), or a combination of both. Asbestos debris may be limited to a few small pieces that are removed under limited quantity discovery” procedures, or may be in a more extensive “debris field” that will be removed under “significant discovery procedures” as described in Sections 11 and 12 of this SOP.

Upon the discovery of any suspected construction debris material, the contractor shall immediately stop excavation activities in that area, and notify the UCD project manager so the condition can be inspected to determine if asbestos contaminated soil is present. These determinations will be made by an asbestos soil inspector which is an EPA accredited and CDPHE certified asbestos building inspector with 6 months soil inspection experience. Where asbestos contaminated soil is identified, this material shall be removed by a qualified contractor with properly trained personnel, in accordance with applicable regulations and procedures described in this SOP.

6 Regulatory Summary and Regulatory References

6.1 CDPHE Hazardous Materials Waste Management Division (HMWMD) – *“Asbestos Contaminated Soils” not associated with the “Built Environment”*

To address asbestos in soil, the Colorado Department of Public Health and Environment’s Hazardous Materials and Waste Management Division (HMWMD) has established specific management requirements for asbestos-contaminated soil under Section 5.5 of the Regulations Pertaining to Solid Waste Disposal Sites and Facilities (6 CCR 1007-2). Disposal of ACM, and work done in asbestos-contaminated soil (ACS), must comply with this regulation. The requirements of Section 5.5 of the Solid Waste Regulations apply to the owner or operator of any property with asbestos-contaminated soil at which soil-disturbing activities are occurring or planned for any area containing asbestos-contaminated soil. The requirements of Section 5.5 are triggered when the owner or operator has reason to believe or suspect the presence of asbestos-contaminated soil at a site, (through confirmation by analysis of observed material that is suspected of containing asbestos), or has reason to believe or suspects that visible asbestos will be encountered. An owner or operator that has no reason to know of or suspect asbestos-contaminated soil at a site does not have a duty to sample or otherwise investigate for asbestos-contaminated soil prior to commencing excavation, or other soil disturbing activities, at the site. It is important to understand that there is no language in the Solid Waste Regulations that requires an owner or operator to perform soil-disturbing activities, or to remediate asbestos-contaminated soil. The regulations include specific requirements that apply if asbestos-contaminated soil is disturbed or will be disturbed.

To supplement the regulation, CDPHE developed a guidance document intended to provide direction to contractors, consultants and property owners who are involved in soil disturbing activities in areas with known or suspected asbestos-contaminated soil, or where asbestos-contaminated soil is discovered. The guidance is meant to assist in compliance with the Solid Waste Regulations, and where applicable, Air Quality Control Commission Regulation No. 8, Part B (5 CCR 1001-10, Part B - Asbestos).

CDPHE Solid Waste Regulations identify two methods for addressing ACS, **Management** and **Remediation**.

1. **Management** is the removal of only that asbestos-contaminated soil necessary to perform the work, without the intent to remove additional soil outside the scope, even where observed. Management of soil in place is included under this activity. Under management, post removal soil sampling is recommended but not required for soil management actions.
2. **Remediation** is the planned removal of all asbestos-contaminated soil, removing soil beyond a particular scope of work to remove visible and analytical documented presence of asbestos. Under remediation, clearance soil sampling is required.

Both Management and Remediation approaches require CDPHE approval of a site specific soils work plan or a standard operating procedures (SOP) plan.

Remediation would be the appropriate action where a “No Further Action” letter is sought from CDPHE, or where a consent order has been issued by CDPHE, or when “closure” documentation is desired, as Management is the more accepted cost effective option to address soil contamination where this “No Further Action” is not required.

Remediation of asbestos-contaminated soil is not required under the Solid Waste Regulations, but may be conducted in accordance with Section 5.5.5 of the Regulations. It should also be noted that sampling of asbestos-contaminated soil is not required under Section 5.5 of the Solid Waste Regulations; however, the information that can be gained from sampling may be beneficial for many projects. In addition, when conducting remediation required by CDPHE (consent order, etc), sampling may be necessary to demonstrate that cleanup objectives have been met. Remediation will only be conducted at AMC where it is the intent to remediate and/or receive a no further action letter.

In accordance with Section 5.5.2 of the Solid Waste Regulations, the following projects are exempt from the requirements of Section 5.5 of the Solid Waste Regulations, but may be subject to other sections of the Solid Waste Regulations or other regulatory programs:

1. In situations where the soil contains solely nonfriable material containing asbestos, that has not been rendered friable, the nonfriable material can be removed from the soil and properly disposed in accordance with Section 5.2 of the Solid Waste Regulations. The surrounding soil would not be considered to be asbestos-contaminated soil, and therefore would not be subject to the requirements of Section 5.5 of the Solid Waste Regulations. The determination that a material is nonfriable must be made by an asbestos Building Inspector who has been certified in accordance with AQCC Regulation No. 8, Part B, and who has a minimum of six (6) months experience in asbestos-contaminated soil inspections (see Section 8.3 Worker Training).
2. The requirements of Section 5.5 of the Solid Waste Regulations do not apply to asbestos abatement of facility components (including pipes, ducts and boilers) conducted in accordance with AQCC Regulation

No. 8, Part B. However, disposal of asbestos must still comply with Sections 5.1 through 5.4 of the Solid Waste Regulations.

3. The requirements of Section 5.5 of the Solid Waste Regulations do not apply to spill response activities that are subject to the requirements of AQCC Regulation No. 8, Part B. As above, disposal of asbestos must still comply with Sections 5.1 through 5.4 of the Solid Waste Regulations.
4. Ambient occurrences of asbestos that are not due to site-specific activities. Ambient occurrences of asbestos may include, but are not limited to, naturally occurring asbestos or the distribution of asbestos from normal wear of automotive products.
5. Projects involving excavations with a total volume of less than 1 cubic yard of soil using low-emission excavation methods such as hand held tools or light equipment.

The exemption for asbestos abatement projects conducted under AQCC Regulation No. 8, Part B, includes asbestos debris that may come into contact with soil during demolition of structures with asbestos-containing materials and materials containing trace amounts of asbestos (including trace soil in crawlspaces, loose fill vermiculite, etc) that can legally remain during demolition and be disposed of as normal demolition debris. Any asbestos debris left behind after the completion of a demolition project and associated site cleanup, would be subject to the requirements of Section 5.5 of the Solid Waste Regulations if disturbed in the future.

6.2 EPA, OSHA DOT and CDPHE Air Pollution Control Division (APCD) “Asbestos/Asbestos Contaminated Soils” associated with the “Built Environment”

The Environmental Protection Agency (EPA), the Occupational Safety and Health Administration (OSHA) and the Colorado Department of Public Health and Environment (CDPHE) define *asbestos-containing material* (ACM) as any material containing greater than 1% asbestos as asbestos-containing material. EPA, OSHA and CDPHE define *friable* materials as those materials that can be crumbled or reduced to powder by hand pressure, whereas *nonfriable* materials cannot. Friable materials are more likely to be released into the air, especially during renovation and demolition of the building. Under EPA and CDPHE regulations, certain types of nonfriable materials (such as tar impregnated roofing and vinyl asbestos floor tile) may remain during normal demolition (provided these materials remain nonfriable during the demolition process) and also may be disposed of as normal demolition debris. In addition drywall joint compound that contains greater than 1% asbestos may remain in a building for demolition and disposal as normal demolition debris provided the joint compound was not used as a surfacing material and the composite result of the drywall and joint compound reported less than 1% asbestos. Additionally, materials containing trace to 1% are not subject to EPA and CDPHE regulations and may remain in a building during demolition and may be disposed of as normal demolition debris. Under these provisions, it is common for asbestos to remain in a building for demolition and for subsequent disposal as normal demolition debris.

ACM is subject to the EPA National Emissions Standards for Hazardous Air Pollutants (NESHAPs) Regulations for Asbestos (40 CFR Part 61) which includes specific provisions for renovation and demolition projects pertaining to the “built” environment, and disposal of asbestos-containing waste material. ACM is subject to the EPA Toxic Substances Control Act (TSCA) which includes provisions for training and certification for asbestos remediation and consulting activities. The CDPHE is presently responsible for administering the EPA NESHAP and TSCA program for Colorado.

ACM is subject to OSHA Construction Industry Standard for Asbestos (29 CFR Parts 1910.1101). Materials containing 1% or less asbestos may be subject to OSHA regulations under certain classes of work activity, or if air concentrations are at or above the personal exposure limit (PEL) of 0.1 f/cc or the excursion limit of 1.0 f/cc. The OSHA asbestos standard includes provision for hazard communication, training, exposure assessment, respiratory protection, engineering controls, medical evaluations, and other provisions.

ACM is subject to Department of Transportation (DOT) regulations for packaging, labeling and transportation of asbestos under 49 CFR Part 173.

ACM is subject to applicable requirements of the CDPHE Air Pollution Control Division's (APCD) Regulation 8. The term **Abatement** is defined by the CDPHE under the Air Pollution Control Division Regulation 8, and includes the removal of asbestos-containing materials covering facility components, which includes discovery wrapped steam line found below grade, transite[®] water pipe, or an abandoned buried boiler covered with asbestos. Removal of asbestos in soil associated with facility components would be subject to the requirements under CDPHE Air Pollution Regulation 8, including contractor licensing, worker certifications, permitting, etc.

1. Removal of asbestos-containing material on a facility component, that is located on or in soil that will be disturbed, shall be conducted (as stipulated under Section 5.5 of the Solid Waste Regulations), in accordance with work practices in AQCC Regulation No. 8, Part B, Section III.O, but is not subject to the permit requirements of AQCC Regulation No. 8, Part B, as long as the total quantity of asbestos-containing material is below the following trigger levels:
 - a) 260 linear feet on pipes,
 - b) 160 square feet on other surfaces, or
 - c) The volume equivalent of a 55-gallon drum.
2. Removal of asbestos-containing material on a facility component with asbestos quantities above the trigger levels is subject to the notification, permit, and abatement requirements of AQCC Regulation No. 8, Part B, and is therefore outside the scope of Section 5.5 of the Solid Waste Regulations, as provided in Section 5.5.2(B) of the regulations.
3. Removal of pieces of asbestos-containing material, that are not on a facility component, and are located on or in soil that will be disturbed, shall be conducted under Section 5.5 of the Solid Waste Regulations, in accordance with work practices in AQCC Regulation No. 8 - Part B, Section III.O. The removal activities would not be subject to the permit requirements of AQCC Regulation No. 8, Part B.

Under EPA NESHAPs/CDPHE APCD regulations, the primary consideration under this SOP is adherence to CDPHE APCD Regulation 8 requirements for the discovery of asbestos-containing materials on buried facility components such as piping, boilers, etc and the proper removal in accordance with the EPA NESHAPs and CDPHE APCD regulations. Under CDPHE APCD regulations, secondary consideration under this SOP is the proper removal of all construction debris including nonfriable materials allowed to remain during demolition, asbestos-containing joint compound (where composite result reported less than 1%) and trace-1% asbestos materials. Where demolition debris is allowed to remain after demolition activities have been completed, any presence of asbestos in the soil would then be subject to the CDPHE HMWD ACS regulations. This issue is addressed in more detail in Section 13 (Special Considerations) of this SOP.

All work on asbestos-containing materials (ACM) must comply with the applicable requirements of EPA, OSHA, DOT and CDPHE APCD asbestos regulations.

6.3 References

- CDPHE. 2006. *Asbestos-Contaminated Soil Guidance Document*. Prepared in draft form April 2006 by the Hazardous Materials and Waste Management Division.
- CDPHE. 2006. *Asbestos-Contaminated Soil Regulations*. Section 5.5 of the Hazardous Materials and Waste Management Division's Regulations Pertaining to Solid Waste Disposal Sites and Facilities
- CDPHE. 2008, Air Quality Control Commission Regulation No. 8, Part B (5 CCR 1001-10, Part B - Asbestos).
- OSHA. *Construction Industry Standards for Asbestos*. 29 CFR 1926.1101

7 Classification of Types of Soil Disturbing Activities

The following are the classifications of soil disturbing activities under this SOP.

1. **“Localized Limited Quantity Shallow Hand Digging-** This covers localized limited quantity (less than 1 cubic yard of soil) shallow hand digging from surface to 24 inches in depth, that is typical in the normal day-to-day operations of the campus, including sprinkler repair, planting shrubs and small potted plants, and installing fence posts/signs, etc.
2. **“Small Scale” Localized Hand/Equipment Excavation-** This covers deeper (greater than 24 inches) localized excavation generating greater than 1 cubic yard of soil, and includes hand digging or small/light equipment (backhoe, mini excavator, tree planters, min-excavators, and hole drilling augers, etc) for minor utility repair, tree planning, etc. With these types of excavations, the work is a very short (day duration), and the soil is typically deposited in the same location from which it is removed, and is not typically subject to relocation.
3. **“Moderate Scale” Localized Equipment Excavation –** This covers larger scale “localized” excavations that involve trenching or pothole excavation typically to install or repair buried utilities. With these types of excavations, the work is a is short to moderate duration (days to weeks), is conducted with a moderate sized “back-hoe” or excavator” and the soil is typically deposited in the same location from which it is removed, and is not typically subject to relocation. An example of this would be utility corridor trenching.
4. **“Large Scale” Equipment Excavation –** This covers largest scale excavations that involve mass excavation of a site, usually for building construction or other site development purposes. With these types of excavations, the work is a moderate to long duration (weeks to months), is conducted with large excavators, scrapers, front end loaders, etc, and the soil is typically subject to relocation on and off-site, with potential for additional soil import, depending on final grade requirements. An example of this would be “mass excavation” performed for construction of a new building.

8 Excavation Notifications

The following table summarized the types of **notifications required prior to conducting soil disturbing activities**.

	Low Potential ACS condition	Moderate to High Potential ACS condition	Known ACS condition
Localized Limited Quantity (less than 3 cubic yards) Shallow Hand Digging (less than 24 inches in depth for sprinkler repair, shrub/planting small potted plants, installing fence posts/signs etc)	No notification required	No notification required	No notification required
Localized Small Scale Hand/Equipment Excavation more than 3 cubic yards and greater than 24 inches in depth (minor utility repair, tree planning, etc)	No notification required	Notification to UCD prior to start	Notification to UCD and CDPHE prior to start
Moderate Scale Localized Equipment Excavation (utility trenching)	Notification to UCD prior to start	Notification to UCD prior to start	Notification to UCD and CDPHE prior to start
Large Scale Equipment Excavation (mass excavation)	Notification to UCD prior to start	Notification to UCD prior to start	Notification to UCD and CDPHE prior to start

CDPHE will be notified within 24 hours of an unexpected ACS and/or ACM discovery. CDPHE will be notified at least 10-days prior to any planned soil-disturbing activity in areas of known ACS and/or ACM. The HMWMD can be notified by using the Notification Form attached to this plan, and emailed to CDPHE contact identified in Section 3 of this SOP. If ACS is encountered and an area reclassified as “known ACS condition” that CDPHE will be notified prior to start or re-start of work.

Additional notification shall be provided to UCD if construction debris is encountered in areas determined to be low potential ACS condition. **Notification to UCD includes notification to UCD Facilities Planning Department contact and UCD Environmental Health and Safety Division contacts as provided in Section 3 of this SOP.** The Contractor shall notify and receive approval from the UCD project manager prior to any soil being exported or imported to the project. Contractor shall coordinate any inspections, spotting, or testing requested by the UCD project manager for any exported or imported soils to the project. For emergency repair projects to utilities, etc, notification will be provided to CDPHE by the next business day.

9 Excavation Planning

Prior to performing any soil disturbance activities, those persons performing the soil disturbing activity shall check the AMC ACS Asbestos Contaminated Soils Classification Site Drawing (Attachment #1) to determine the classified ACS condition for the area where soil disturbing activities will occur. Comply with notification, training and work procedures provisions of this document based on the classified condition for the area where excavation will occur which will be classified into one of the following three categories:

- *Low Potential ACS Condition (areas shaded green)*
- *Moderate to High Potential ACS Condition (areas shaded yellow)*
- *Known ACS Condition (shaded coded red)*

The following soil spotting activities will be utilized during all excavation activities for moderate to large scale excavation activities when moderate to high potential ACS conditions exist:

1. All surface work areas will be pre-inspected by the asbestos soil inspector prior to commencement of soil disturbance activities.
2. Excavation Area: conduct a subsurface visual inspection for asbestos material during excavation. The asbestos soil inspector will inspect all areas of the excavation as removal of soil proceeds, and will inspect the bottom of the excavation for visible ACM.
3. Stockpile and Backfill Areas: closely inspect stockpiled area as soil is dumped/piled.

Where ACS is identified and impacted by planned excavation, the characterization, removal and disposal of contaminated soil shall be conducted in accordance with the provisions of this SOP. Once the asbestos soil inspector has delineated the ACS boundaries (depth and extent through visual inspection characterization protocols as provided in Section 11 of this SOP), the Contractor may continue excavation in other non-ACS areas with continued spotting by an asbestos soil inspector.

For localized limited quantity (less than 1 cubic yard) shallow (less than 24 inches) hand digging for normal day-to-day operations, including sprinkler maintenance, installation of signs/posts, planting of small plants and shrubs, etc, these activities are exempt from this SOP since these activities typically occur in newly constructed areas with shallow digging occurring in the top fill layer placed during new construction, which has a low potential to contain asbestos debris, and less than 1 cubic yard by hand-digging is exempted under CDPHE HMWMD regulations. Notification shall be provided to UCD if construction debris is encountered under these exempted activities.

For additional planning purposes and as a reference, an historical site map is provided in Attachment #2 that shows the building and steam tunnel locations for the former Fitzsimons Army Medical Center. Attachment #3 contains a flow chart that summarizes the key components of this SOP document.

10 Training Requirements

10.1 SOP circulation

The following entities/persons involved with soil disturbing activities shall be provided a copy of this SOP prior to performing work.

1. Those performing soil disturbing activities in areas with moderate to high potential to encounter ACS
2. Those providing awareness soil training
3. Those providing soil inspection or soil spotting activities during normal excavation activities.
4. Those performing soil disturbing activities in a known ACS condition area
5. Those providing air monitoring and inspection associated with soil disturbing activities in a known ACS condition area.

10.2 Awareness Training

For areas with *moderate to high* potential to encounter ACS, all those persons involved with the excavation regardless of size shall be provided on the job hazard communication awareness (awareness) training for those individuals associated with the soil disturbing activities as follows:

“On-the-job” asbestos soils awareness training as defined in Section 5.5.6 of the Solid Waste Regulations will be provided to workers directly involved in soil-disturbing activities on sites where there is known ACS or a “reason to believe” ACS may be encountered. The training will address such topics as history and background of asbestos, identifying types of asbestos, health effects, engineering controls, and actions to take when suspect asbestos materials are encountered. The training will be conducted with oversight and curriculum development by an asbestos building inspector, asbestos supervisor or project designer.

The awareness training must provide information necessary for the individuals to perform their duties in a way that ensures compliance with the requirements of Section 5.5 of the Solid Waste Regulations. The training must be conducted by an Asbestos Supervisor, Building Inspector or Project Designer, certified in accordance with AQCC Regulation No. 8, Part B, and who has a minimum of six (6) months experience in asbestos-contaminated soil management.

10.3 ACS Soil Disturbance Training

For **moderate to large scale excavation** activities in areas with **known ACS**, provide on the job hazard communication awareness training for those individuals associated with the soil disturbing activities. In addition personnel overseeing, directing, inspecting and/or handling asbestos or asbestos-contaminated soil during soil excavation activities shall have the following minimum training and certifications:

1. At least one (1) trained supervisor (competent person) shall be on site during excavation activities (current EPA Asbestos Supervisor Certification)
2. CDPHE HMWMD training required for persons performing asbestos-contaminated soil disturbing activities including on the job asbestos contaminated soil awareness training and training in accordance with OSHA standard 1926.1101 (k) (9) (vii) for those performing soil disturbing activities in an area with asbestos waste or asbestos contaminated soil (EPA Asbestos Supervisor/Worker training is recommended).
3. A current annual physical with medical release / respirator usage form and respirator fit test.

This training requirement applies to equipment operators but is not required for drivers of trucks carrying contaminated material for disposal to approved landfills. Drivers are only required to complete the awareness training.

For **Small Scale excavation** activities with **known ACS**, provide awareness training for those individuals associated with the soil disturbing activities. In addition personnel overseeing, directing, inspecting and/or handling asbestos or asbestos-contaminated soil during small scale soil excavation activities shall have the following minimum training and certifications:

1. At least one (1) trained supervisor (competent person) shall be on site during excavation activities.
2. CDPHE HMWMD training required for persons performing asbestos-contaminated soil disturbing activities including on the job asbestos contaminated soil awareness training and training in accordance with OSHA standard 1926.1101 (k) (9) (vii) for those performing soil disturbing activities in an area with asbestos waste or asbestos contaminated soil (Training Equivalent with OSHA Class III training for “small scale short duration” activities that will disturb asbestos recommended).
3. A current annual physical with medical release / respirator usage form and respirator fit test.

10.4 ACS Inspection and Air Monitoring Training

Individuals performing soil inspection and identification of asbestos in soil must have a current asbestos Building Inspector certification in accordance with AQCC Regulation No. 8, Part B, and must have a minimum of six (6) months experience conducting asbestos-contaminated soil inspections. Individuals with this level of training and experience are referred to in this SOP as “asbestos soil inspectors”.

Individuals preparing and signing Soil Characterization and Management Plans must have a current Asbestos Project Designer certification in accordance with AQCC Regulation No. 8, Part B.

Individuals performing asbestos air monitoring associated with asbestos-contaminated soil disturbing activities must have a current Air Monitoring Specialist certification in accordance with AQCC Regulation No. 8, Part B

10.5 Additional Considerations

In addition, individuals with the potential for exposure to asbestos fibers should be trained in the proper usage of personal protective equipment and have a current annual physical with a medical release/respirator usage form in accordance with the employer’s medical surveillance program. Personal exposure air monitoring should be conducted in accordance with the employer’s exposure assessment program.

11 ACS Characterization Protocols and Trigger Levels

The following summarizes the potential conditions that may be encountered during soil disturbing activities at the AMC:

1. Localized areas of **friable and/or nonfriable** asbestos debris in soil that constitute “significant quantity” as provided under the “trigger level” of this plan. Triggering “major” response procedures as provided in this plan.
2. Localized areas of **friable and/or nonfriable** debris in soil that constitute “limited quantity” as provided under the “trigger level” portion of this plan, triggering “minor” spill response during planned excavation spotting activities.
3. Localized areas with construction debris with no asbestos debris, such as brick, metal, and PVC pipe, and non-asbestos suspect debris (confirmed by bulk sampling).
4. Localized areas where no visible construction debris, or visible suspect asbestos containing materials are present.

To provide a basis for appropriate level of assessment (limited vs. significant) and management for discovered asbestos debris, the following summarizes specific trigger levels to be used under this SOP. These trigger levels are “**limited quantity discovery**” and “**significant quantity discovery**” of **visible friable and/or nonfriable asbestos debris** and have corresponding assessment and response actions based on the limited or significant finding:

11.1 Limited Quantity Material Discovery Assessment and Management Protocol

Entry into Limited Quantity Assessment and Management Protocols: Where up to 3 pieces (with multiple pieces of asbestos within a few inches of each other to be treated as one piece of asbestos) of friable and/or nonfriable asbestos debris are identified within a 10-foot radius, record the locations with a GPS unit, photograph and log pertinent information such as location, description of material, type of debris, etc.

Exit from Limited Quantity Assessment and Management Protocols: Carefully wet and remove the visible debris and 3 cubic feet of soils surrounding each debris piece. All debris will be adequately wetted, and removed by appropriately trained and protected personnel. All debris and associated soil will be placed into appropriately labeled disposal bags, for proper disposal based on the material friability.

11.2 Significant Quantity Material Discovery Assessment and Management Protocol

Entry into Significant Quantity Assessment and Management Protocols: Where greater than 3 pieces (with multiple pieces of asbestos within a few inches of each other to be treated as one piece of asbestos) of friable and/or nonfriable asbestos debris are identified within a 10-foot radius, this will constitute a debris field. The asbestos soil inspector will conduct surface and subsurface visual assessment with the assistance of excavation equipment to determine the extent and depth of the asbestos debris field. All asbestos debris field corner points will be documented with a GPS unit, on a drawing and

by photograph. Photograph and log pertinent information such as type of debris, quantity, etc.

Exit from Significant Quantity Assessment and Management Protocols: Removal of debris field based on a visual determination to the extent of excavation, or removal of *extent of find (EOF) plus 1 foot of soil, and removal of depth of find (DOF) plus 1 foot of soil for subsurface contamination, and removal of extent of find (EOF) plus 1 foot of soil where only surface contamination is identified.* Where visible friable and/or nonfriable asbestos debris is still observed at the extent of planned excavation, the area will be over excavated by 1 foot, and then covered with a geotechnical membrane and labeled/demarcated as asbestos-contaminated soil, and covered with 1 foot of clean fill. The boundary will be recorded with a GPS unit, on a drawing, and by photograph.

11.3 Visual Characterization for Significant Discovery

Site characterization (surface and subsurface visual assessment) will be conducted by using visual inspection to identify depth and extent of visible significant debris using potholing and trenching techniques for asbestos debris. Soil sampling and analysis is not part of the characterization process under this SOP, and any collection and analysis of soil samples for asbestos content requires written authorization from UCD.

11.4 Surface Investigation

Surface investigation for areas identified as having potential asbestos-containing debris will be conducted for suspect asbestos debris. Surface investigation will include sampling suspect asbestos-containing material, or will assume material is asbestos-containing. Marker paint and flags will be used to demarcate locations of any suspect debris. Locations will be identified with a GPS device. The surface investigation will include photographing and logging pertinent information such as location, type of debris, quantity, etc.

11.5 Investigation Personal Protective Equipment

At a minimum, appropriate PPE must be worn when doing asbestos inspections or otherwise accessing an area suspected or known to contain asbestos. At a minimum, asbestos soil inspectors performing the inspection and/or personnel performing the pickup of non-friable asbestos must wear disposable booties and disposable rubber gloves, which should then be discarded as asbestos waste prior to exiting the site. At a minimum, asbestos soil inspectors performing the inspection and/or personnel performing the pickup of friable asbestos must wear a half-face air-purifying respirator with HEPA cartridge filtration, disposable protective suite, disposable booties and disposable rubber gloves. Disposable protective equipment should then be discarded as asbestos waste prior to exiting the site. Additional protective equipment shall be used as appropriate.

11.6 Demarcation of Discovery Locations and ACS Boundaries

Locating debris and other site conditions by GPS where specified in this SOP is considered the primary method for documenting these locations, but distance measurement (XYZ coordinate) descriptions may be used where a site grid is utilized or where locations are adjacent to structures or features. Grid/Structure reference points shall be documented with GPS in the event grid markers or structures are removed.

12 Limited Quantity ACS Management Procedures

Where the asbestos soil inspector visually observes up to three pieces of friable and/or nonfriable asbestos debris within a ten (10) foot radius, follow the procedures listed below.

For **nonfriable** asbestos material, adequately wet, using hand-removal methods only, gather and place the material and approximately 12 inches of surrounding soil in 6-mil poly bags. For **friable** asbestos material, adequately wet, using hand-removal methods only, gather and place material and 3 cubic feet of surrounding soil in 6-mil poly bags (double bags). Continue work with extra attention to possible additional asbestos in that vicinity. Stage waste bags in a lined drum or roll-off container. Dispose of waste as asbestos contaminated waste in accordance with CDPHE regulations and this SCMP.

All personnel involved in the removal of Limited Quantity asbestos debris will wear at a minimum a half-face air purifying respirator with HEPA filtration, and disposable protective suit, disposable overbooties and disposable gloves. Decontamination of all tools and equipment involved in the removal of asbestos debris is required prior to leaving the work area. Disposable suits, overbooties and gloves shall be disposed of as asbestos waste.

13 Significant Quantity ACS Management Procedures where only Nonfriable Asbestos Material is Present

Where the asbestos soil inspector visually observes more than three pieces nonfriable asbestos debris within a ten (10) foot radius, follow the procedures listed below.

13.1 Soil Wetting and Stabilization

The Work Area will be adequately wetted to prevent any fugitive dust emissions that may be generated during initial setup and mobilization into the area. The Contractor shall use water hoses from a tank truck or directly from a fire hydrant or other water source. Water will be applied at low pressure so as to not generate dust or splattering. During all soil disturbing activities, wetting of soil will be sufficient to ensure soils are adequately wet (no visibly dry soil and no visible emissions) throughout the soil disturbing activities.

13.2 Dust and Emissions Control

General dust control will be achieved by use of water trucks that will regularly spread water on all access roads throughout the project site to ensure no visible dust generation by vehicle traffic during soil disturbance activities.

Whenever contaminated soil and debris are being impacted, the Contractor will ensure that no emissions are generated. UCD's representative will be on site to monitor the moisture of the soil being skimmed during removal and will ensure that it is adequately wet (and to observe for any visible emissions). An asbestos soil inspector will conduct these visual inspections.

If emissions are observed during the removal process, activities will immediately cease and work practices will be reviewed and modified by the Contractor. The Consultant will log all instances where visible dust emissions occurred and immediately notify UCD and CDPHE by phone and in writing, of all occurrences, and will obtain any direction from UCD and CDPHE.

13.3 PPE

During the actual soil disturbance activity, all persons within the designated work area shall utilize appropriate personal protective equipment, including appropriate respiratory protection with a minimum half face respirator with HEPA filtration required anytime active soil disturbance is occurring, protective full body tyvek[®] suit with attached hood and booties, gloves, rubber boots, and other protective wear as appropriate based on conditions (cold stress, heat stress, insects, etc)

13.4 Removal/Excavation

The Contractor will remove adequately wet soil in lifts with the lift thickness is determined by the depth of the adequately wet soil. The application of amended water to work area will be completed in accordance with all applicable regulations, variances, the work plan, and the on-site observations by the Consultant. Polyethylene sheeting will be placed over uncontaminated soils in the swing radius of the excavator or along the transport route of loading equipment to prevent cross-contamination. Care will be taken to avoid contamination of the excavating equipment. This will be accomplished by driving and keeping excavating equipment on non-contaminated soil.

Equipment that comes in contact with contaminated soil, or that was within the designated work area will be decontaminated. Conduct work with appropriate phasing/sequencing that will minimize cross-contamination potential.

13.5 Wind and Work Stoppage Conditions

Soil disturbance operations will not be conducted if winds produce visible emissions of dust or create dust when moving equipment or soil.

13.6 Environmental Monitoring

During the execution of the soil removal, the AMS will collect air samples to assist in determining the adequacy of the engineering and environmental controls employed at the site. Air monitoring will be conducted during ACS significant discovery soil removal activities where only nonfriable material is visible. All air samples will be collected by a CDPHE certified Air Monitoring Specialist (AMS).

The air monitoring is described below.

1. **Sampling Media:** Air samples will be collected by drawing air through a 25-millimeter mixed cellulose ester filter, 0.8-micron pore size, with an open-faced, long cowl using low-flow personal sampling pumps at approximately 2 liters per minute (or flow rate to provide a sufficient LOQ/LOD). Each low-volume pump will be fitted with a computer microchip, which electronically regulates airflow and allows a fixed flow rate of air to pass over the face of the filter. The flow rate and the volume of air passed through the filter will be determined based on the National Institute for Occupational Safety and Health (NIOSH) 7400 analytical method. Each pump will be calibrated before and after the collection of each sample using a primary standard.
2. **Sample Analysis:** Sample analyses will be performed by a microscopist using a phase contrast microscope (PCM) according to the NIOSH 7400 Method. The microscopist will be a CDPHE certified Air Monitoring Specialist (AMS) and a participant in the NIOSH Proficiency Analytical Testing Program and have been deemed proficient. Analyses of transmission electron microscopy (TEM) air samples will be submitted to a National Institute for Standards and Technology National Voluntary Laboratory Accreditation Program accredited laboratory using TEM according to Asbestos Hazard Emergency Response Act protocol.
3. The daily air monitoring sampling scheme will be as follows:
 - a. Air samples will be strategically placed as close to work area without impeding equipment and worker activity, and will be collected continuously during excavation and loading operations and submitted the same day for PCM analysis. **A total of 5 samples will be collected per shift per work area.**
 - b. Of the 5 samples collected, three (3) perimeter samples will be placed to triangulate the work area, moving as necessary to follow the active “area-of-disturbance”, but *remaining fixed in relation to each other*. One (1) additional perimeter “floating sample” will be placed downwind from work activities, where potential fiber emissions are most likely to be detected. All perimeter samples shall be collected as close to the “point of disturbance” as possible, without subjecting the air monitoring equipment to damage from the operations. One (1) additional sample, to be considered the potential worst-case scenario “area equivalent” sample, will be collected on personnel closest to disturbance operations, such as the person operating the water hose.
 - c. The results from these samples for comparison to 0.01 f/cc (and presence of asbestos for when analyzed by TEM) and should not be construed as “OSHA exposure assessment air samples”.
 - d. **Performance Based Air Sampling:** Five (5) samples, including personnel and perimeter samples, will be submitted for PCM analysis. If analysis yields results with detectable fiber levels (based on fiber count) then TEM analysis will be conducted on the two (2) highest PCM samples for the first 3 days of each nonfriable excavation event. If no asbestos fibers are detected after the first 3 days of each event, then TEM analysis of the two (2) highest PCM samples will be reduced, to be conducted randomly twice per week. The AMS will determine on which two days *TEM analysis* will be conducted. TEM analysis will continue to be performed on any sample with PCM results exceeding 0.01fibers/cc. .
4. PCM verbal results will be made available by the start of the next business day or as soon as practical after the start of the next business day. TEM verbal results will be made available within 24-hours of receipt of samples by the laboratory, and written results will be made available within 24 hours from the time the verbal result is received. UCD and CDPHE will be immediately notified if any sample results show any concentration of airborne fibers. If any asbestos fibers are detected by TEM, all investigative activities will be stopped and engineering controls will be evaluated by Contractor and Consultant, and will be discussed with UCD and CDPHE to determine if changes in engineering controls or additional PPE are required.
5. As an alternative to Environmental Air Monitoring for significant quantity nonfriable excavation, where soil sampling is performed in areas containing only visible nonfriable asbestos debris (per a soil sampling plan as agreed upon by UCD and CDPHE), and where soil sampling data demonstrates that no asbestos is present in the soil, and excavation work practices will not render the nonfriable material friable, environmental air monitoring may be reduced to PCM on workers only with the written approval of UCD and CDPHE.

13.7 Personal Air Monitoring

Air sampling of personnel is an employer based responsibility, and as such shall be the responsibility of each employer associated with soil disturbing activities. The “area equivalent”

samples collected on personnel are interpreted as “worst case area” samples and are not intended to provide OSHA exposure information, but can be used by employers for general informational purposes.

13.8 Truck/Container Staging/Lining and Waste Loading

All truck drivers will be instructed to close all windows and shut-off air delivery systems (fans on air-conditioning and heating systems) when entering the loading area. All travel and positioning of waste transport Truck/Trailers on the site should be visually verified clean soil to minimize the need for decontamination procedures. At the loading location, install a ten-mil polyethylene sheeting or thicker “lay-down pad” that will be placed on the ground under dumpsters/trucks to catch any spilled material. Spilled material will be cleaned up immediately and not allowed to dry out or accumulate. Additional poly shall be draped over trailer tires/fenders to minimize the need for decontamination after loading. After the load has been secured, and the load cover tarp is installed, the poly sheeting lay down loading pad will be properly decontaminated using wet wipe and or HEPA vacuuming methods. The loaded transportation truck may then proceed down the designated exit route.

13.9 Waste Transportation and Disposal

Containers of nonfriable asbestos waste, asbestos-contaminated soil with visible nonfriable asbestos, or ACS with no visible asbestos will be labeled, in accordance with the requirements of Section 5.2 of the Solid Waste Regulations. In accordance with the disposal requirements for nonfriable asbestos waste at least one 6-mil polyethylene liner/sheeting will be in trucks used for transport of soil that contains visible nonfriable asbestos. Polyethylene liners/sheeting should be designed and sized for the container to be used and should be folded over sides of trailers or containers to protect against contamination during loading and to facilitate decontamination. After loading, the liners/sheeting will be sealed and mechanically fastened in a manner that ensures that it remains intact and leak-tight during transportation and disposal operations. Containers of nonfriable asbestos waste, asbestos-contaminated soil with visible nonfriable asbestos, and asbestos-contaminated soil with no visible asbestos, shall be labeled noting “asbestos, danger” and the generator, and placed on top of sealed liner.

In addition, Department of Transportation (DOT) asbestos placards shall be placed on all four vertical sides of the container or vehicle being used for transport of ACS. The Contractor should direct the schedule of transportation of asbestos-contaminated soil. When loaded, each truck should be assigned a manifest to serve as the shipping document for that particular load.

Asbestos-contaminated soil shall be transported and disposed in a leak tight container in accordance with the CDPHE disposal requirements. Documentation stating that the soil originating from the site will not be used as daily cover or sold as clean fill shall accompany each load of asbestos-contaminated soil removed from the site.

Disposal of asbestos-contaminated soil will be conducted in accordance with the following requirements, in accordance with Section 5.5.7 of the Solid Waste Regulations:

1. Asbestos-contaminated soil containing only visible nonfriable asbestos, that has not been rendered friable, will be disposed of as nonfriable asbestos in accordance with Section 5.2 of the Solid Waste Regulations.
2. Asbestos-contaminated soils containing no visible asbestos will be disposed in a manner similar to nonfriable asbestos waste, as described in Section 5.2 of the Solid Waste Regulations.

13.10 Personnel Decontamination

A fully functioning 3-chamber decontamination trailer (or equivalent) will be placed outside the work zone to function as a remote shower location, with a clean room and an equipment room. All workers involved in removal/packaging ACS will be double suited while in the work area and will shed one suit prior to leaving the work area and immediately proceed to the decontamination facility. All workers will decontaminate per OSHA regulations and CDPHE Regulation No. 8. Decontamination water will be filtered using a 5 micron filter, or in accordance with local requirements if more stringent, prior to disposal to the sanitary sewer.

13.11 Equipment Decontamination

All equipment and tools that come into contact with, or are used for removal of ACS will be decontaminated (free of all visible dust and debris) using wet cleaning (fire hose for trackhoe equipment, wet rags for hand tools, etc) and HEPA vacuuming methods (interior of equipment cab, etc), prior to leaving the work zone. Equipment decontamination will be conducted within a decontamination station constructed adjacent to the work zone. The decontamination station will be constructed of 10-mil polyethylene sheeting (and other materials as necessary, such as EPDM rubber roofing, etc) in such a way as to capture all contaminated material and wastewater from the decontamination process. All waste water from the decontamination station will be filtered to a minimum of 5-microns (or in accordance with local requirements if more stringent, prior to discharge to a sanitary sewer), or may be used for wetting ACS.

13.12 Final Inspection Procedures

As the project progresses, visual inspection will be performed to ensure that all observable asbestos-containing materials have been removed from the soil surface. During removal of soil, the soil will be removed in a manner that will provide a flat, even surface (with no spoil piles) for visual inspection. The inspections will be performed for the surface area removed that day, as a preliminary inspection. Due to the wet nature of the removal and the soil, adequate drying time is required before a final visual inspection can be conducted

The removal of soil in the debris field area will be considered complete when the visible asbestos-containing material has been removed and an asbestos soil inspector makes a final decision that all contaminated soil in the debris field has been removed to depth and extent of excavation (where remaining visible material will be covered with a membrane and labeled), or depth of find plus 1 foot of soil (DOF+1) and extent of find plus 1 foot of soil (EOF+1).

13.13 Managing ACS left in place

Where visible asbestos containing material is observed at the depth and extent of excavation, 1 additional foot of soil shall be removed, the area shall be covered with a geotech membrane,

labeled as asbestos contaminated soil, and then the membrane shall be covered with 1 foot of clean fill to bring back to desired grade/level. Prior to covering with clean fill, photographs will be collected from each compass point of the boundary, and the corner points of the boundary shall be obtained using measurements for a control point or with a GPS device.

14 Significant Quantity ACS Management Procedures where Friable Asbestos Material is Present

Where the asbestos soil inspector visually observes more than three pieces friable asbestos debris within a ten (10) foot radius, follow the procedures listed below.

14.1 Site Control, Demarcation, Fencing and Wind Screening

The Work Area will be demarcated on all four sides using a movable/portable wind barrier to prevent wind dispersal of soil during excavation activities. Moveable/portable wind barriers will be placed on all four sides and immediately adjacent to the point of excavation, and will be of adequate height and configuration (size) to minimize wind soil dispersal at the point of excavation. For smaller areas or highly mobile removal activities, moveable “directional” mobile wind fencing may be used, but must be positioned upwind and adjacent to soil removal activities at all times. Where only directional wind fencing is used, asbestos barrier tape shall be installed to identify the remaining boundary of the Work Area (where wind fence is not positioned)

14.2 Protection of Adjacent Structures

When the abatement area is close to occupied structures, external critical barriers may need to be constructed. All openings in the structure, including windows, doorways, vents or other openings will be sealed with 6-mil poly.

14.3 Soil Wetting and Stabilization

The Work Area will be adequately wetted to prevent any fugitive dust emissions that may be generated during initial setup and mobilization into the area. The Contractor shall use water hoses from a tank truck or directly from a fire hydrant or other water source. Water will be applied at low pressure so as to not generate dust or splattering. During all soil disturbing activities, wetting of soil will be sufficient to ensure soils are adequately wet (no visibly dry soil and no visible emissions) throughout the soil disturbing activities.

14.4 Dust and Emissions Control

General dust control will be achieved by use of water trucks that will regularly spread water on all access roads throughout the project site to ensure no visible dust generation by vehicle traffic during soil disturbance activities.

Amended water and or stabilization agents will be applied for dust control within all disturbed ACS areas. The Contractor will maintain the dust control process throughout the course of the project during soil disturbing activities. Removal of soils and debris will be done with heavy equipment which has been adapted to have a water misting system installed on the equipment to minimize dust emissions at the point of removal. Water will be applied in a manner that does not cause run-off or splattering. In addition, a water misting system will be constructed to wet the material at the point of loading into the dumpster prior to final packaging.

Whenever contaminated soil and debris are being impacted, the Contractor will ensure that no emissions are generated. UCD's representative will be on site to monitor the moisture of the soil being skimmed during removal and will ensure that it is adequately wet (and to observe for any visible emissions). An asbestos soil inspector will conduct these visual inspections.

Site management and inspectors will monitor the quantity of surface area disturbed at any given time; also the amount of surface not stabilized will be kept to the minimum quantity necessary for meaningful work to occur. If site conditions change so that dust suppression becomes questionable on the amount of disturbed area, a portion of that area will be stabilized and work will proceed on a reduced area.

If emissions are observed during the removal process, activities will immediately cease and work practices will be reviewed and modified by the Contractor. The Consultant will log all instances where visible dust emissions occurred and immediately notify UCD and CDPHE by phone and in writing, of all occurrences, and will obtain any direction from UCD and CDPHE.

14.5 PPE

During the actual soil disturbance activity, all persons within the designated work area shall utilize appropriate personal protective equipment, including appropriate respiratory protection with a minimum half face respirator with HEPA filtration required anytime active soil disturbance is occurring, protective full body tyvek[®] suit with attached hood and booties, gloves, rubber boots, and other protective wear as appropriate based on conditions (cold stress, heat stress, insects, etc)

14.6 Removal/Excavation

Utilizing an excavator, mini excavator or backhoe with a bucket mounted spray bar system; the soil excavation will proceed within the designated work area. The spray bar system will consist of nozzles inside the back top edge of the bucket and two outside the bucket with nozzles spray pattern overlapping that will provide adequate wetting to eliminate fugitive dust, but avoid splatter or drift from spraying. Additional hand wetting will be used to eliminate fugitive emissions, but avoid splatter or drift from spraying.

The Contractor will remove adequately wet soil in lifts with the lift thickness is determined by the depth of the adequately wet soil. The application of amended water to work area will be completed in accordance with all applicable regulations, variances, the work plan, and the on-site observations by the Consultant. Polyethylene sheeting will be placed over uncontaminated soils

in the swing radius of the excavator or along the transport route of loading equipment to prevent cross-contamination. Care will be taken to avoid contamination of the excavating equipment. This will be accomplished by driving and keeping excavating equipment on non-contaminated soil.

Equipment that comes in contact with contaminated soil, or that was within the designated work area will be decontaminated. Conduct work with appropriate phasing/sequencing that will minimize cross-contamination potential.

14.7 Wind and Work Stoppage Conditions

Soil disturbance operations will not be conducted if winds produce visible emissions of dust or create dust when moving equipment or soil. All wind speed measurements will be taken at locations in close proximity to, and representative of, the work area in which the soil is being handled.

Shutdown conditions: Soil removal/disturbance operations will immediately and temporarily cease when one or more of the following 4 conditions have been met:

1. Any wind gust reaching or exceeding 20 mph as determined by hand-held instruments;
2. Sustained wind speeds reaching or exceeding 12 mph averaged over a period of 10 minutes;
3. Winds are producing visible emissions or creating movement of dust or debris in or near the removal/disturbance area, or
4. Winds are impacting on the ability of engineering controls to work as designed.

During wind-related work shutdowns, other work activities not involving soil removal or disturbance (e.g., lining dumpsters) may continue.

Resume Conditions: Soil disturbance activities may resume after all of the following 4 conditions have been met:

1. All wind gust readings for a period of 20 minutes drop below 20 mph as determined by hand-held instruments;
2. Sustained wind speeds are below 12 mph averaged over a period of 20 minutes;
3. Winds are no longer producing visible emissions or creating movement of dust in or around the removal/disturbance area, and
4. Winds are not impacting on the ability of engineering controls to work as designed.

14.8 Environmental Monitoring

During the execution of the soil removal, the AMS will collect air samples to assist in determining the adequacy of the engineering and environmental controls employed at the site. Air monitoring will be conducted during ACS significant discovery soil removal activities where visible friable asbestos material is present. All air samples will be collected by a CDPHE certified Air Monitoring Specialist (AMS). The air monitoring is described below.

1. Sampling Media: Air samples will be collected by drawing air through a 25-millimeter mixed cellulose ester filter, 0.8-micron pore size, with an open-faced, long cowl using low-flow personal sampling pumps

at approximately 2 liters per minute (or flow rate to provide a sufficient LOQ/LOD). Each low-volume pump will be fitted with a computer microchip, which electronically regulates airflow and allows a fixed flow rate of air to pass over the face of the filter. The flow rate and the volume of air passed through the filter will be determined based on the National Institute for Occupational Safety and Health (NIOSH) 7400 analytical method. Each pump will be calibrated before and after the collection of each sample using a primary standard.

2. Sample Analysis: Sample analyses will be performed by a microscopist using a phase contrast microscope (PCM) according to the NIOSH 7400 Method. The microscopist will be a CDPHE certified Air Monitoring Specialist (AMS) and a participant in the NIOSH Proficiency Analytical Testing Program and have been deemed proficient. Analyses of transmission electron microscopy (TEM) air samples will be submitted to a National Institute for Standards and Technology National Voluntary Laboratory Accreditation Program accredited laboratory using TEM according to Asbestos Hazard Emergency Response Act protocol.
3. The daily air monitoring sampling scheme will be as follows:
 - a. Air samples will be strategically placed as close to work area without impeding equipment and worker activity, and will be collected continuously during excavation and loading operations and submitted the same day for PCM analysis. **A total of 8 samples will be collected per shift per work area.**
 - b. Of the 8 samples collected, four (4) samples will be arranged at the 4 points of the compass surrounding the work area with two (2) additional samples deemed as "perimeter floating samples". The perimeter floating samples will be placed in areas where emitted asbestos fibers are most likely to be detected (downwind from work activities). Two potential worst-case scenario "area equivalent" samples will be collected on at least 2 workers who are expected to have the greatest potential exposure to asbestos during abatement operations. The results from these samples are for comparison to 0.01f/cc (and presence of asbestos for when analyzed by TEM) and should not be construed as "OSHA exposure assessment air samples".
4. Eight (8) samples, including personnel and perimeter samples, will be submitted for PCM analysis. If analysis yields results with detectable fiber levels (based on fiber count) then TEM analysis will be conducted on two (2) highest PCM samples to evaluate engineering controls. After two (2) weeks of TEM sampling, the analytical results and engineering controls will be assessed to determine if adequate controls are in place. If controls are deemed adequate by UCD and CDPHE, the number of *TEM samples* may be reduced as approved by UCD and CDPHE. On an ongoing project basis, any sample with PCM results exceeding 0.01 fibers/cc must be analyzed by TEM. For large areas of disturbance, additional perimeter monitoring points shall be added if the active area of soil disturbance is larger than approximately 1 acre in size. One additional monitoring point should be added for each additional 200 linear feet of perimeter (approximately 1 sample per additional ¼ acre increase in area). For active areas of soil disturbance greater than 1 acre, additional samples shall be analyzed by TEM at a minimum rate of 25% of the total number of samples collected, based on highest PCM results. However, TEM analysis is not required if PCM results are non-detect (based on fiber count).
5. PCM verbal results will be made available by the start of the next business day or as soon as practical after the start of the next business day. TEM verbal results will be made available within 24-hours of receipt of samples by the laboratory, and written results will be made available within 24 hours from the time the verbal result is received. UCD and CDPHE will be immediately notified if any sample results show any concentration of airborne fibers. If any asbestos fibers are detected by TEM, all investigative activities will be stopped and engineering controls will be evaluated by Contractor and Consultant, and will be discussed with UCD and CDPHE to determine if changes in engineering controls or additional PPE are required.

14.9 Personal Air Monitoring

Air sampling of personnel is an employer based responsibility, and as such shall be the responsibility of each employer associated with soil disturbing activities. The "area equivalent" samples collected on personnel are interpreted as "worst case area" samples and are not intended to provide OSHA exposure information, but can be used by employers for general informational purposes.

14.10 Truck/Container Staging/Lining and Waste Loading

All truck drivers will be instructed to close all windows and shut-off air delivery systems (fans on air-conditioning and heating systems) when entering the loading area. All travel and positioning of waste transport Truck/Trailers on the site should be visually verified clean soil to minimize the need for decontamination procedures. At the loading location, install a ten-mil polyethylene sheeting or thicker “lay-down pad” that will be placed on the ground under dumpsters/trucks to catch any spilled material. Spilled material will be cleaned up immediately and not allowed to dry out or accumulate. Additional poly shall be draped over trailer tires/fenders to minimize the need for decontamination after loading. After the load has been secured, and the load cover tarp is installed, the poly sheeting lay down loading pad will be properly decontaminated using wet wipe and or HEPA vacuuming methods. The loaded transportation truck may then proceed down the designated exit route.

To accomplish proper characterization of soil (preliminary visual inspection and verification visual inspection at staging area), movement of soil to staging areas for subsequent loading, transportation and disposal is necessary. Staged soil must be stabilized when loading is not occurring. Upon removal of staged ACS placed on “non-ACS area”, the contractor shall remove an additional 12 inches of soil to address any cross-contamination that may have occurred to the non-ACS area.

14.11 Waste Transportation and Disposal

Containers of friable asbestos waste, or asbestos-contaminated soil with visible friable asbestos, shall be labeled, in accordance with the requirements of Section 5.3 of the Solid Waste Regulations. In accordance with the disposal requirements for friable asbestos waste (Section 5.3.5(A) of the Solid Waste Regulations) at least two 6-mil polyethylene liners/sheeting shall be used for soil that contains visible friable asbestos. Polyethylene liners/sheeting should be designed and sized for the container to be used and should be folded over sides of trailers or containers to protect against contamination during loading and to facilitate decontamination. After loading, both liners/sheeting should be mechanically fastened and sealed separately. The liners/sheeting shall be sealed in a manner that ensures that they remain then leak-tight during transportation and disposal operations.

In addition, Department of Transportation (DOT) asbestos placards shall be placed on all four vertical sides of the container or vehicle being used for transport of ACM/ACS. The Contractor should direct the schedule of transportation of asbestos-contaminated soil. When loaded, each truck should be assigned a manifest to serve as the shipping document for that particular load.

Asbestos-contaminated soil shall be transported and disposed in a leak tight container in accordance with the CDPHE disposal requirements. Documentation stating that the soil originating from the site will not be used as daily cover or sold as clean fill shall accompany each load of asbestos-contaminated soil removed from the site.

Disposal of asbestos-contaminated soil will be conducted in accordance with the following requirements, in accordance with Section 5.5.7 of the Solid Waste Regulations:

1. Asbestos-contaminated soils containing visible friable asbestos will be disposed in a leak tight container as friable asbestos waste in accordance with the requirements of Section 5.3 of the Solid Waste Regulations.

14.12 Personnel Decontamination

A fully functioning 3-chamber decontamination trailer (or equivalent) will be placed outside the work zone to function as a remote shower location, with a clean room and an equipment room. All workers involved in removal/packaging of friable or significant quantities of nonfriable ACM will be double suited while in the work area and will shed one suit prior to leaving the work area and immediately proceed to the decontamination facility. All workers will decontaminate per OSHA regulations and CDPHE Regulation No. 8. Decontamination water will be filtered using a 5 micron filter, or in accordance with local requirements if more stringent, prior to disposal to the sanitary sewer.

14.13 Equipment Decontamination

All equipment and tools that come into contact with, or are used for removal of ACS will be decontaminated (free of all visible dust and debris) using wet cleaning (fire hose for trackhoe equipment, wet rags for hand tools, etc) and HEPA vacuuming methods (interior of equipment cab, etc), prior to leaving the work zone. Equipment decontamination will be conducted within a decontamination station constructed adjacent to the work zone. The decontamination station will be constructed of 10-mil polyethylene sheeting (and other materials as necessary, such as EPDM rubber roofing, etc) in such a way as to capture all contaminated material and wastewater from the decontamination process. All waste water from the decontamination station will be filtered to a minimum of 5-microns (or in accordance with local requirements if more stringent, prior to discharge to a sanitary sewer), or may be used for wetting ACS.

14.14 Final Inspection Procedures

As the project progresses, visual inspection will be performed to ensure that all observable asbestos-containing materials have been removed from the soil surface. During removal of soil, the soil will be removed in a manner that will provide a flat, even surface (with no spoil piles) for visual inspection. The inspections will be performed for the surface area removed that day, as a preliminary inspection. Due to the wet nature of the removal and the soil, adequate drying time is required before a final visual inspection can be conducted

The removal of soil in the debris field area will be considered complete when the visible asbestos-containing material has been removed and an asbestos soil inspector makes a final decision that all contaminated soil in the debris field has been removed to depth and extent of excavation (where remaining visible material will be covered with a membrane and labeled), or depth of find plus 1 foot of soil (DOF+1) and extent of find plus 1 foot of soil (EOF+1).

14.15 Managing ACS left in place

Where visible asbestos containing material is observed at the depth and extent of excavation, 1 additional foot of soil shall be removed, the area shall be covered with a geotech membrane,

labeled as asbestos contaminated soil, and then the membrane shall be covered with 1 foot of clean fill to bring back to desired grade/level. Prior to covering with clean fill, photographs will be collected from each compass point of the boundary, and the corner points of the boundary shall be obtained using measurements for a control point or with a GPS device.

14.16 Spill Control

Where asbestos contaminated soil is spilled during loading or transport, the Contractor shall immediately ensure the spilled material is immediately collected in accordance with wetting and emission control provisions of this SCMP. For spills that occur on clean soil, remove 12 inches of soil under spill area as precautionary measure. For spills that occur on hard surfaces such as asphalt roadways or concrete parking lots, provide wet cleaning and HEPA vacuuming until all visible dust and debris have been removed.

Where water run-off occurs resulting in visible erosion and sediment transfer from asbestos contaminated soil areas to non-asbestos contaminated soil areas, remove top 12 inches of soil where the visible erosion and sediment deposition occurred.

14.17 Erosion Control

To control wind erosion of ACS, use of silt fencing or wind fencing may be used, where appropriate. Stabilize asbestos containing soil with friable debris by covering with magnesium chloride (or equivalent soil stabilizer) or 6-mil poly until removal can occur. Securely fasten poly sheeting to prevent removal by the wind.

To control water erosion, the use of silt fencing, erosion control mats, straw wattles or equivalent erosion control methods shall be used in areas where run-off is likely. Where ACS will remain, cover with geotech membrane, and then cover with 12 inches of clean fill and cover with appropriate vegetative growth or ground cover to prevent erosion.

15 Special Considerations

15.1 Emergency Buried Utility Repair Projects

Specific provisions of this SOP require some planning and response time that may not be appropriate in an emergency response situation to repair a buried utility. This section identifies the minimum requirements under this SOP for the first 24 hours of excavation and repair, to ensure that necessary repairs can be made to buried utilities promptly in an emergency situation where the utility must be repaired immediately (which may include evening and weekend work), where ACS is encountered during the emergency response, only worker protection, adequate wetting and no visible emission provisions of this SOP will apply within the first 24 hours, with remaining provisions including material characterization, soil training, air monitoring, disposal, etc to take effect after the first 24 hours of the excavation and repair. By ensuring adequate wetting and no visible emissions during emergency excavation during the first 24-hours, this will allow necessary work to continue, and will provide a window for implementing remaining

provisions of this SOP including testing of suspect materials and where ACS is identified, and for implementing management actions under this SOP. Where suspect material is identified in soil that has been excavated during the emergency repair, this soil shall not be placed back into the hole/pit until characterization can be conducted by an asbestos soil inspector.

15.2 Importing and Exporting Soil

The Contractor shall notify and receive approval from the UCD project manager prior to any soil being exported or imported to the project. Contractor shall coordinate any inspections, spotting, or testing requested by the UCD project manager for any exported or imported soils to the project.

15.3 Building Demolition Debris Removal Verification

To ensure demolition debris is removed during the demolition phase in accordance with applicable regulations, an asbestos soil inspector will conduct a site inspection during the final stage of demolition to determine if all demolition debris has been removed. As a precautionary measure, as part of the final demolition site cleaning, a layer of clean soil should be removed to ensure no construction debris remains upon completion of the demolition process as verified by inspection by an asbestos soil inspector, with the exception of non-asbestos-containing/contaminated “structural” fill such as concrete and brick as approved by UCD.

15.4 Soil Stockpiling Management Procedures

Stockpiling of asbestos contaminated soils will only occur under CDPHE and UCD approval, as removal of contaminated soil will be under a direct load approach unless otherwise approved by UCD and CDPHE. When soil movement and stockpiling is necessary, based on site logistics, stockpiled soil must be stabilized and covered when not in use, and must not be allowed to remain on site longer than 5 working days.

For excavation and stockpiling of non-asbestos contaminated soils that are subject to “soil spotting provisions” (moderate to high potential ACS), an asbestos soil inspector will be present at all areas where stockpiled soils are placed, and will be in radio communication with the asbestos soil inspector inspecting soils at the excavation point to ensure prompt and efficient response to discovery of visible ACM debris at either location.

15.5 Management Practices for Significant Discovery of only Nonfriable materials

Where only nonfriable materials are observed (no friable debris) in a significant discovery “debris field”, the following are required procedures:

1. Ensure material and soil is adequately wet and no visible emission occur during excavation and loading activities.
2. Packaging and disposal as nonfriable asbestos containing waste material.

15.6 Soil Sampling

The primary method for determining asbestos contaminated soil under this SOP and under CDPHE HMWMD regulation is visual identification of suspect material that is confirmed or presumed to be asbestos. Soil sampling is considered an optional activity and will be conducted only with UCD written authorization to conduct soil sampling on the campus. There are two primary situations where UCD may authorize soil sampling:

1. Soil sampling to provide general information about imported or exported soils as part of the management procedures under the SOP.
2. UCD written authorization to conduct soil sampling in conjunction with “Remediation” actions (as provided in Attachment #5) conducted to remove the full extent and depth of asbestos contaminated soil from a specified area. Remediation soil sampling may include “baseline” characterization for soil sampling collected prior to a remediation action, and will include collection of “clearance” (post-removal) soil sampling to verify removal of all asbestos (including trace amounts in soil as determined by PLM analysis).

Refer to Attachment #4 for surface soil sampling and analysis procedures.

15.7 Remediation

If the objective of an ACS removal activity is remediation of a specific location to remove the complete extent and depth of asbestos in soil at a specific location, including trace in soil as determined by PLM analysis, or for the purpose of obtaining a no further action determination under some other regulatory framework, such work must be in accordance with the remediation plan provided as a supplement to this SOP in Attachment #5. The remediation plan integrates the sampling and analysis plan (SAP) provided in Attachment #4 and describes soil handling and soil clearance (visual and bulk sampling) criteria. Refer to Attachment #5 for surface remediation procedures.

16 Project Reporting

Upon completion of soil disturbing activities, to aid in future management of site and any remaining ACS conditions known to exist, a close out report will be provided to the UCD to document work performed, and any ACS material known to exist that will remain for management.

The project close-out report shall include the following minimum components:

1. Property description and description of areas with asbestos-contaminated soils
2. Description of soil disturbing activities involving ACS (emission control procedures) and non-ACS conditions
3. Description of all field operations or daily logs
4. Containment logs (where appropriate)
5. Air Monitoring logs and analytical results associated with ACS removal actions
6. Description/results of all asbestos bulk sampling events, including sample locations descriptions and sample diagram/drawing showing sample locations
7. Analytical results associated with bulk sampling events
8. Disposal summaries and manifests
9. Maps showing excavation profiles

10. Documentation of asbestos left in place including drawings, photographs and GPS coordinates for corner points of known ACS.
11. Photographs showing pre-, during and post excavation/removal conditions
12. Accreditation and Certification documentation for activities covered under the Work Plan (Inspector, Air Monitoring Specialist, Supervisor, and Worker)

17 SOP Review and Revision

17.1 SOP Review

Annually, the UCD Facilities Planning Department contact and UCD Environmental Health and Safety Division contact as provided in Section 3 of this SOP shall review this SOP with an asbestos accredited/certified Project Designer with 6-month asbestos soil experience to identify any needed revisions to this SOP.

17.2 SOP Review

Based on annual review, any revisions to the SOP shall be submitted to CDPHE as a “revised” SOP with a new revision number and revision date for CDPHE review and approval.

18 Attachments

Attachment #1	ACS Classification and AMC Boundary Drawing (and Site Survey Drawings)
Attachment #2	Historical Buildings and Steam Tunnels Site Drawing
Attachment #3	SOP Flow Chart
Attachment #4	Soil Sampling and Analysis Plan (SAP)
Attachment #5	Remediation Plan
Attachment #6	CDPHE Notification Summary and Notification Forms

ATTACHMENT 1

ACS CLASSIFICATION AND AMC BOUNDARY SITE DRAWING AND SITE SURVEY DRAWINGS

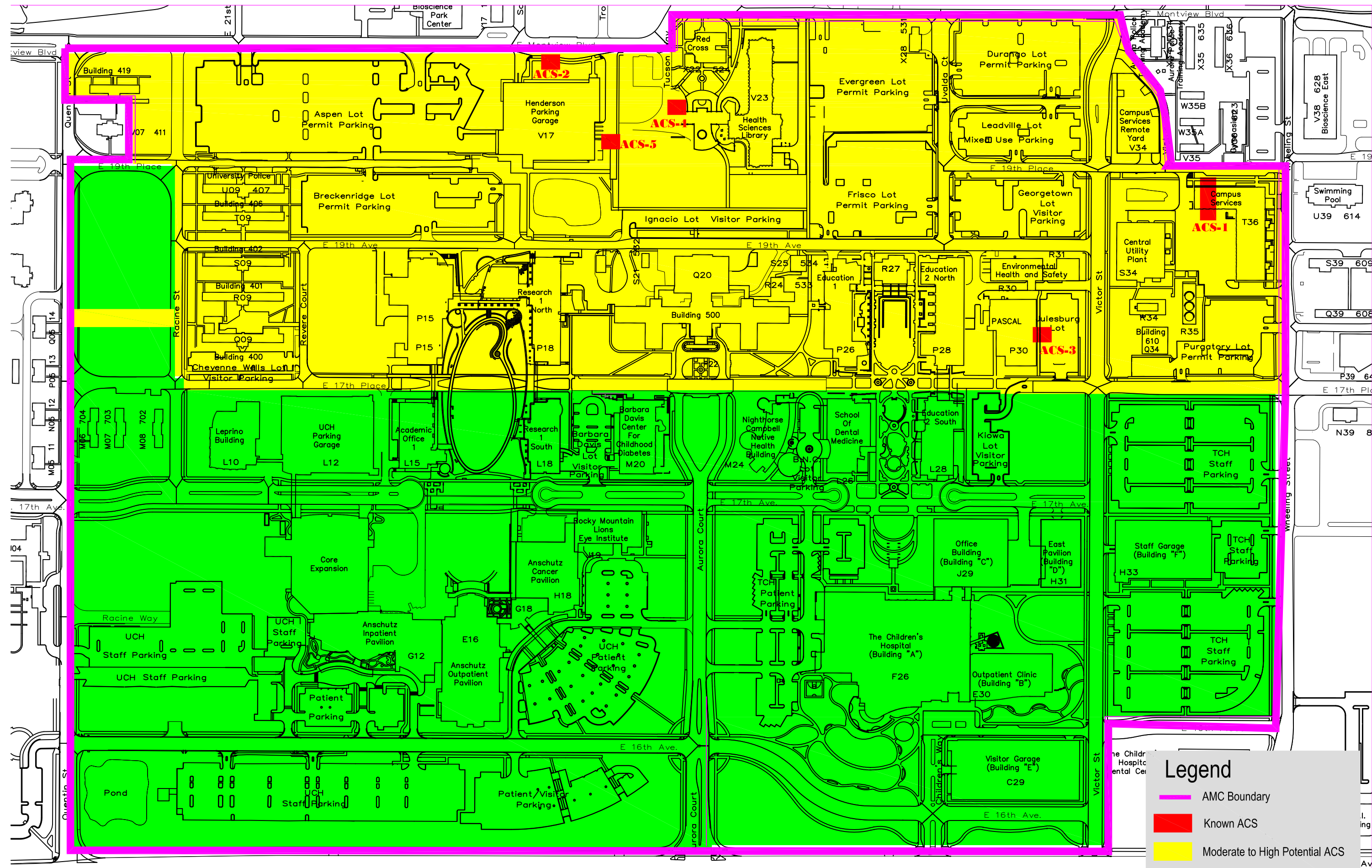

Legend

- AMC Boundary
- Known ACS
- Moderate to High Potential ACS
- Low Potential ACS

ATTACHMENT 1 - AMC ACS POTENTIAL SITE DRAWING

UNIVERSITY OF COLORADO DENVER

AURORA, COLORADO

LEGEND

	EASEMENT		ALIQUOT CORNER
	SECTION LINE		WITNESS CORNER
	QUARTER SECTION LINE		CONTROL POINT
	FRACTIONAL SECTION LINE		BENCHMARK
	PROPERTY LINE (REGENTS OF THE UNIVERSITY OF COLORADO)		CALCULATED POSITION
	LEASE PARCEL (AS DESCRIBED)		
	COP PARCEL (AS DESCRIBED)		

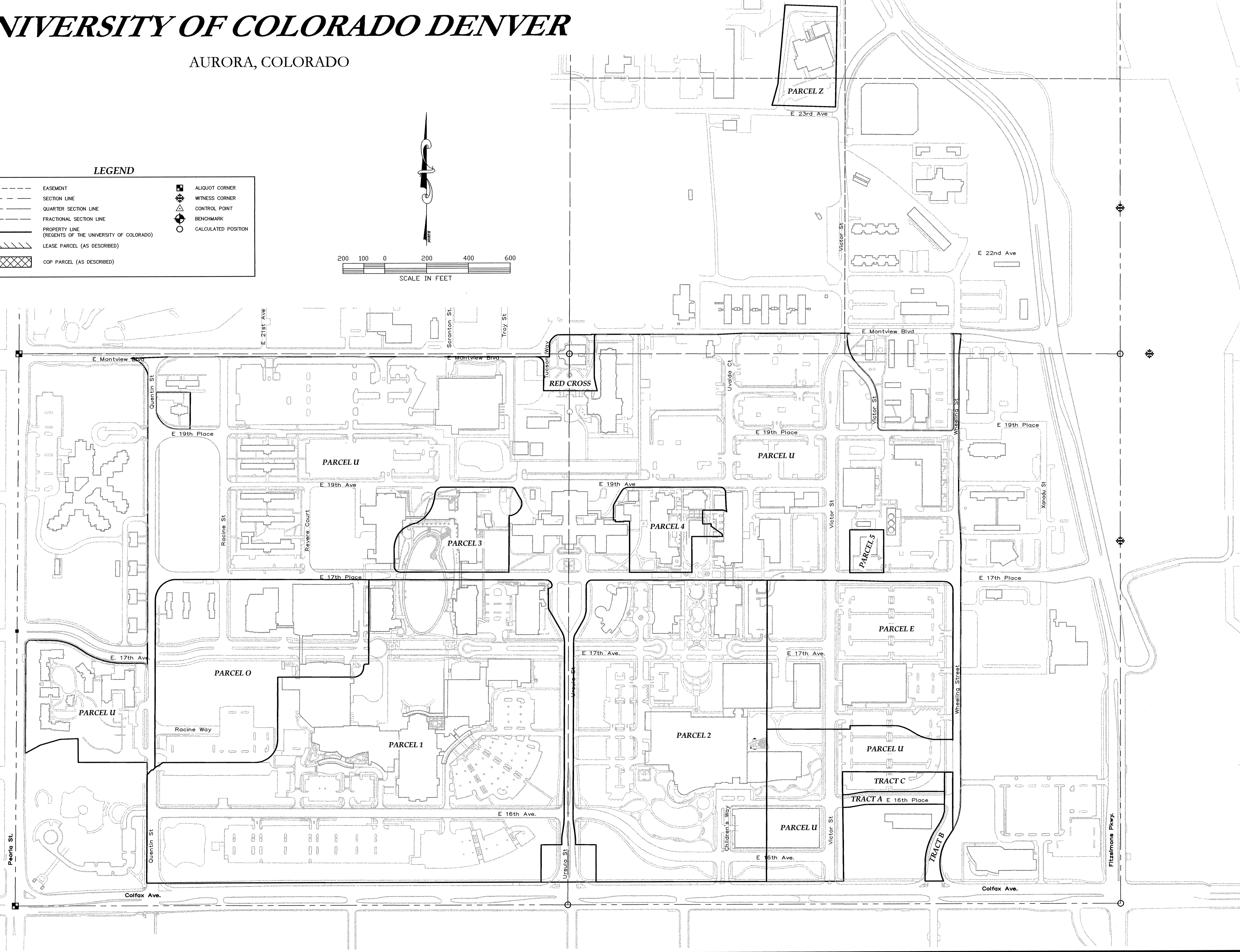
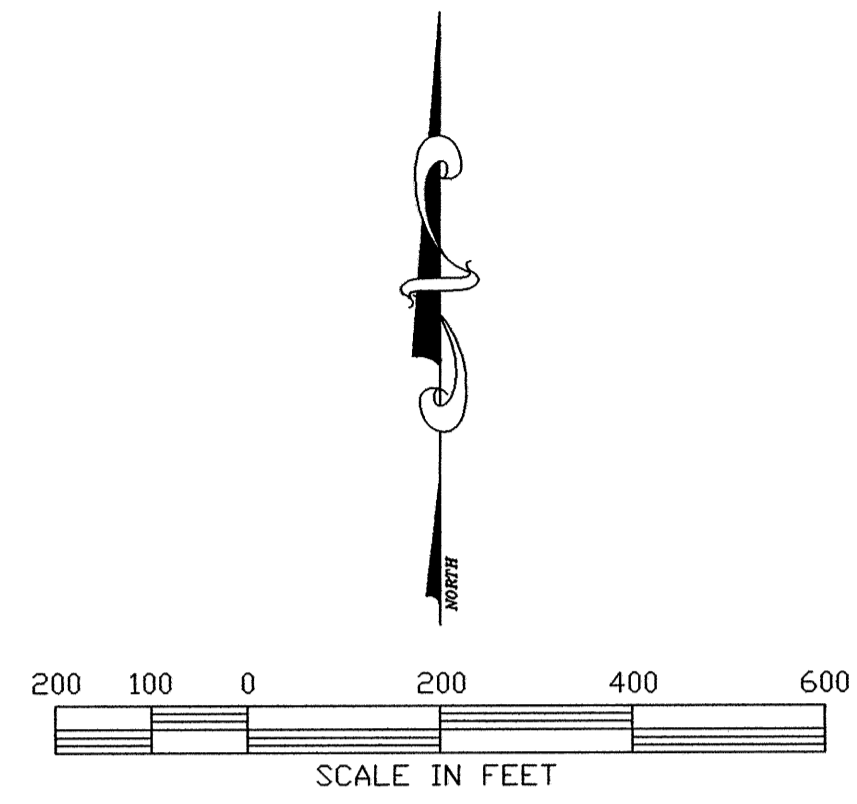

DATE:	10-20-08
FILE NAME:	2008312BASE
SCALE:	1"=200'
DRAWN BY:	BTB
CHECKED BY:	BTB

KING SURVEYORS, INC.
 650 E. Garden Drive | Windsor, Colorado 80550
 phone: (970) 686-5011 | fax: (970) 686-5821



REVISIONS:	DATE:

CONVEYED PARCELS MAP
 FOR
 UNIVERSITY OF COLORADO DENVER
 1945 N. WHEELING STREET
 AURORA, COLORADO 80045

PROJECT #:
2008312

3

H:\2008312\map\2008312BASE.dwg, 11/22/2008 4:46:39 PM, btb

UNIVERSITY OF COLORADO DENVER

AURORA, COLORADO

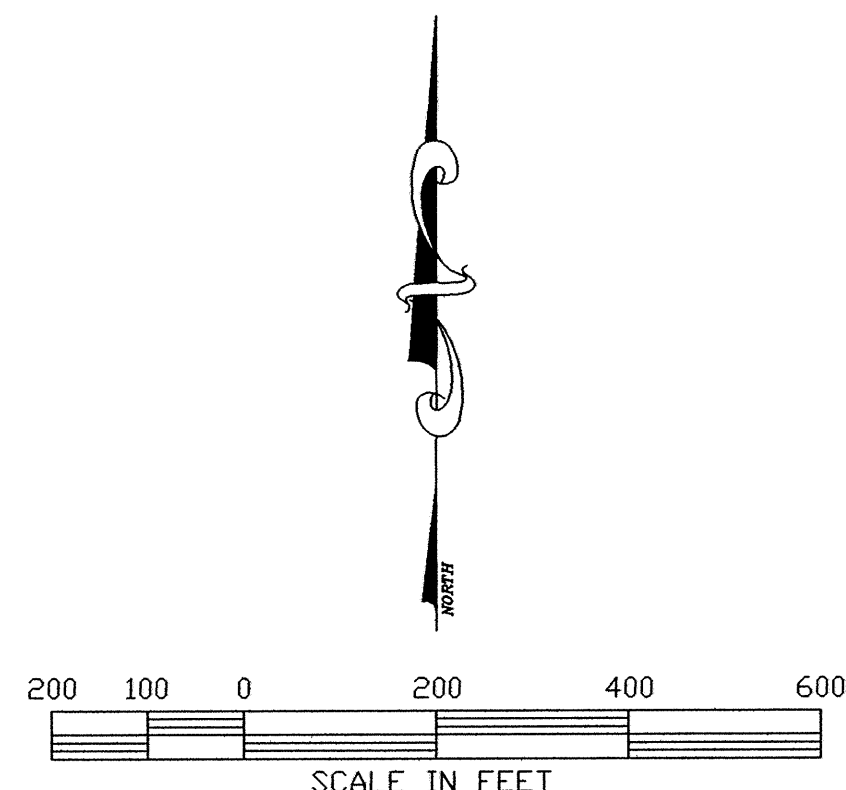

LEGEND			
	EASEMENT		ALIQUOT CORNER
	SECTION LINE		WITNESS CORNER
	QUARTER SECTION LINE		CONTROL POINT
	FRACTIONAL SECTION LINE		BENCHMARK
	PROPERTY LINE (REGENTS OF THE UNIVERSITY OF COLORADO)		CALCULATED POSITION
	LEASE PARCEL (AS DESCRIBED)		
	COP PARCEL (AS DESCRIBED)		

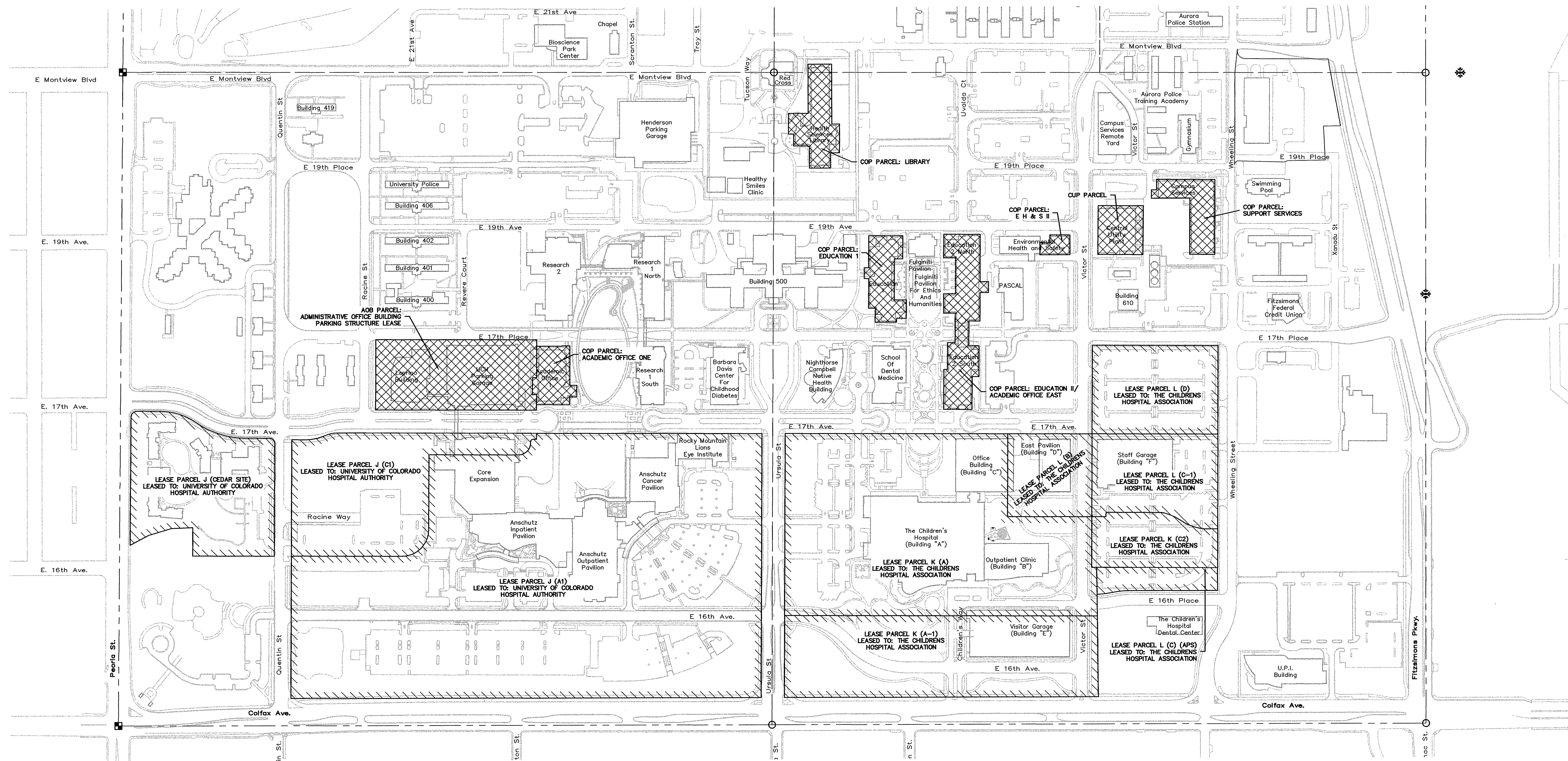

KING SURVEYORS, INC.
 650 E. Garden Drive | Windsor, Colorado 80550
 phone: (970) 686-5011 | fax: (970) 686-5821

REVISIONS:	DATE:

LEASED PARCELS & COP PARCELS MAP
 FOR
 UNIVERSITY OF COLORADO DENVER
 1945 N. WHEELING STREET
 AURORA, COLORADO 80045

PROJECT #: 2008312

ATTACHMENT #2

**HISTORICAL BUILDING AND STEAM TUNNEL
SITE DRAWING**

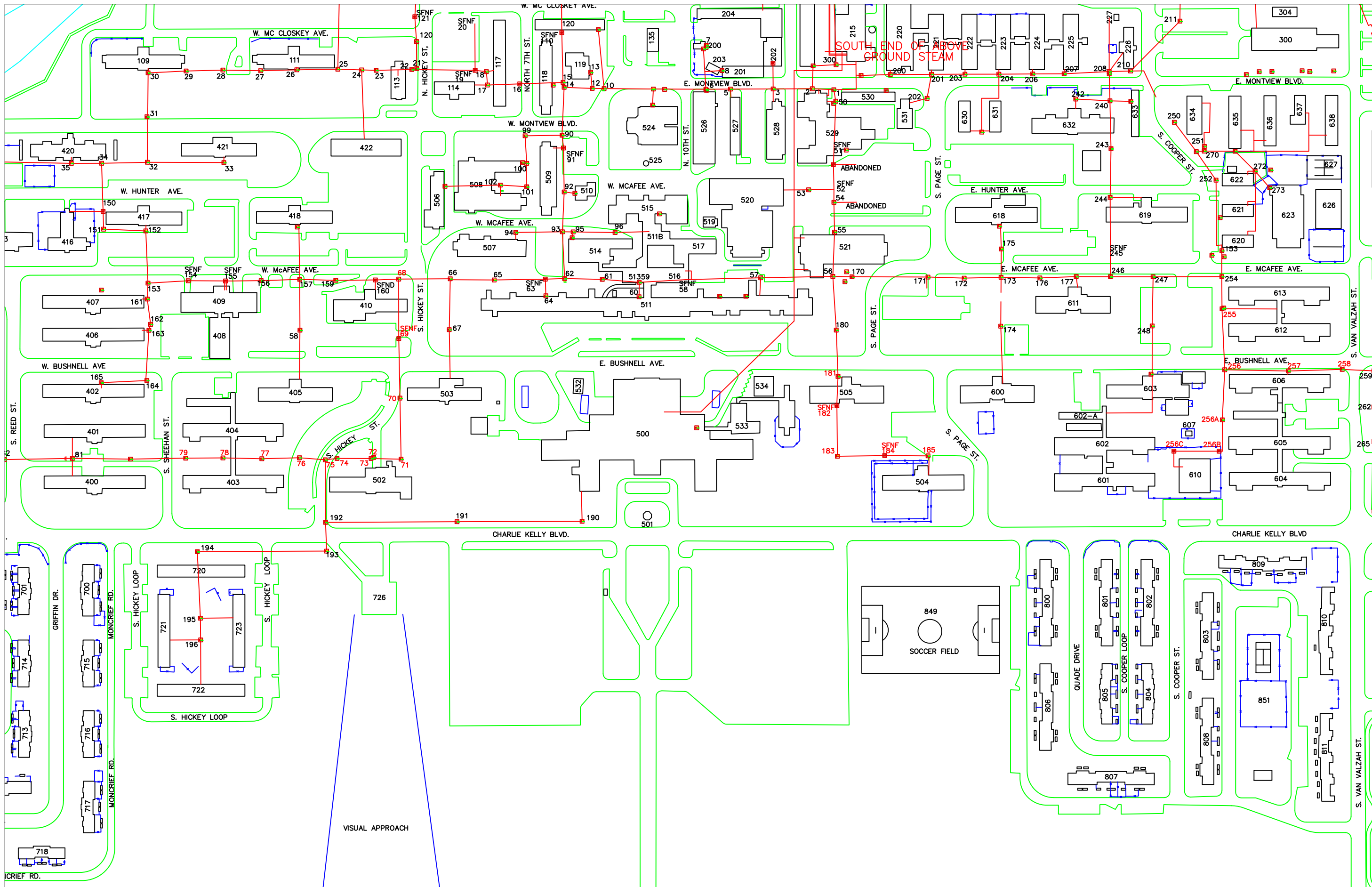

ATTACHMENT 2 - FITZSIMONS HISTORICAL BUILDING AND STEAM TUNNEL SITE DRAWING (UCD AREA)

ATTACHMENT #3

SOP FLOW CHART

AMC ACS SOP

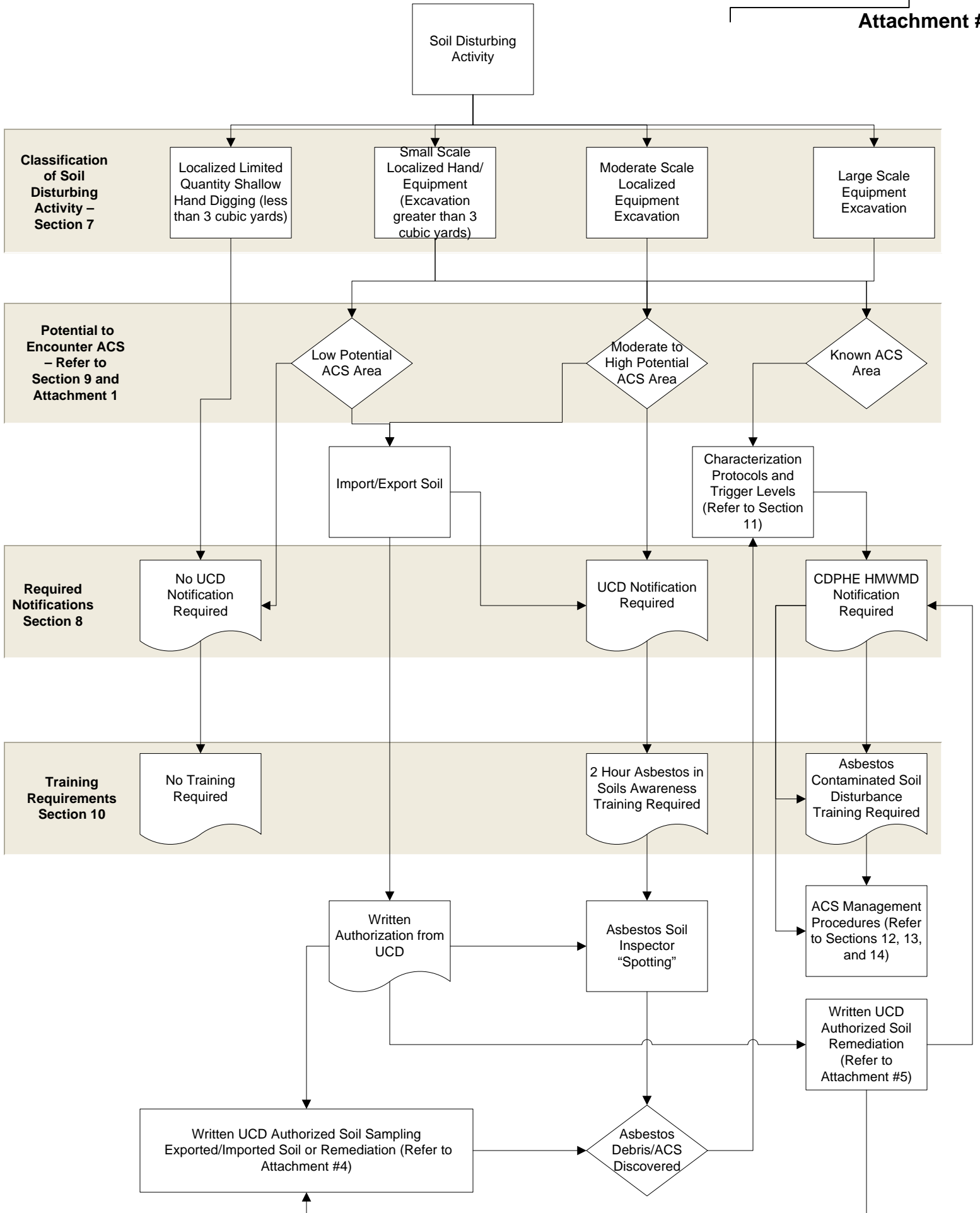

ATTACHMENT #4

SOP SUPPLEMENTAL PROCEDURES SOIL SAMPLING AND ANALYSIS PLAN (SAP)

General

1. Sample aliquots should be collected using a scooping device (stainless steel spoon or equivalent), and transferred to a composite sample container.
2. When all aliquots have been collected, the composite sample container should be sealed and labeled with a sample number unique to the boring from which the sample was collected. The sample should be homogenized by the laboratory prior to analysis.
3. A field sampling form or log book entry should be maintained for each sample. The form or log book entry should contain the location, date and time of each sample, a description of the type of and friability of any suspect material encountered, and any observations made during sample collection.
4. Proper chain-of-custody protocols should be followed for all samples collected.

Analytical Procedures

1. Soil samples should be analyzed by PLM for bulk asbestos samples (Method – EPA/600/R-93/116). The samples should be homogenized by the laboratory prior to sample analysis.

Surface Soil Sampling

1. Divide the area to be inspected into a grid, using stakes or paint to mark grid nodes. The area of each grid square will be determined based on the size of the site, and existing knowledge of the extent and concentration of surface asbestos;
2. Grids are (50' x 50') on an X and Y axis utilizing planned north with the south west corner of each grid being the reference point for each grid site wide. X axis designation is numerical and Y axis grid designation is alphabetical.
3. Each grid point is identified in the lower left (Southwest) corner with a 48" wood lathe with pink ribbon alpha numerically (i.e. B15, CA12).
4. Sub-grids (25' x 50') rectangle grids within each (50' x 50') grid are identified with pin flags alpha numerically (i.e. B15-1, CA12-2).
5. Where grids extend beyond a scope of work boundary and/or property boundary, this boundary will be designated with a string line to delineate scope in partial grids (where grids overlay on scope of work or property boundary).
6. Using flags, paint or GPS, mark locations of any suspected asbestos found;
7. Record locations of suspected asbestos found using a map, log or other documentation. The absence of asbestos in a grid square will also be documented;
8. Place suspected asbestos material in a sample bag, adequately wetting it prior to disturbing it; and record time and date, location and description of material collected.
9. A composite aliquot soil sample will be collected within each sub-grid 1,250 square feet (25' x 50') by an asbestos soil inspector. The asbestos soil inspector will collect ten aliquots of surface soil (top 1 inch) within each sub-grid. Two sample aliquots will be collected from the southwest

quadrant, southeast quadrant, northwest quadrant, northeast quadrant, and the relative center of the sub-grid (totaling ten aliquots per sub-grid). A grid will be considered an asbestos contaminated soil grid where soil sampling data reports the presence of asbestos in any sub grid within that grid (thus progressive analysis may be used to create sample sets for each grid, with a positive stop used where analysis shows asbestos present (eliminating the need to analyze the second sub grid).

10. Samples will be placed in a sample jar, labeled, and location, time, date will be documented.
11. The sample will be homogenized at the laboratory;
12. Follow proper chain of custody protocols.

Subsurface Soil Sampling - Borings

1. A composite sample should be collected from each soil boring. The sample should be made up of five (5) to ten (10) aliquots representative of the soil boring. The actual number of aliquots may vary depending on the depth of sampling and the conditions observed.

Subsurface Soil Sampling – Potholes and Trenches

1. Collect a composite sample made up of five (5) to ten (10) aliquots representative of the soil encountered in the trench or pothole. The actual number of aliquots may vary depending on the depth of sampling and the conditions observed. In addition, it may be warranted to collect separate samples from various strata, with aliquots collected from individual strata, to better characterize observed conditions.

Informational Soil Samples for Imported/Exported Soil

1. The asbestos soil inspector will collect composite samples comprised of 10-point aliquots from 10% of the total number of loads dumped (for imported soils) and/or loaded (for exported soils). Soils sampled for informational purposes shall be managed in an appropriate manner (stockpiled by day, area, etc) to allow appropriate management of soil based on soil sampling data. All soil samples will be submitted to an accredited laboratory for PLM analysis on a “rush” turnaround.

Interpretation of Sampling Data

1. Samples reporting no asbestos detected shall be interpreted as non-ACS, and samples reporting the presence of asbestos shall be considered ACS.

ATTACHMENT #5

SOP SUPPLEMENTAL PROCEDURES REMEDIATION PLAN

Where the intent is to remediate (removal all visible debris and asbestos in soil to a concentration of no asbestos detected in the soil, based on soil sampling), the following supplement to the SOP provides specific remediation provisions.

The following provisions identified in Section 12 of the SOP shall apply to ACS surface soil remediation (soil removal, packaging, transportation and disposal) procedures:

- Notifications Planned Asbestos-contaminated Soil Disturbance
- Limited Quantity Discovery Management and Disposal
- Site Control, Demarcation, Fencing and Wind Screening
- Protection of Adjacent Structures
- Soil Wetting and Stabilization
- Dust and Emissions Control
- PPE
- Equipment/Engineering Controls
- Removal/Excavation
- Soil Stockpiling
- Wind and Work Stoppage Conditions
- Environmental Monitoring
- Personal Air Monitoring
- Truck/Container Staging/Lining and Waste Loading
- Waste Transportation and Disposal
- Personnel Decontamination
- Equipment Decontamination
- Final Inspection Procedures

All ACS identified based on visual characterization (extent and depth) of find, shall be removed plus an additional 12 inches of soil beyond the extent of find (EOF) and 12 additional inches beyond the depth of find (DOF) which identifies the 3-dimension box of soil removed under the remediation.

After removal to EOF and DOF based on visual and preliminary soil sampling data, post remediation “surface clearance” soil sampling will be conducted in accordance with the Soil Sampling and Analysis Plan (Attachment #4) of this SOP, on a grid by grid basis. Any grid reporting the presence of asbestos will be considered to have “failed” and will require removal of additional twelve (12) inches of soil, and the “clearance process will be repeated until “no asbestos detected” is reported for that grid, after which that grid will then have deemed to “pass”. Once all grids in the delineated area have been characterized, remediated, and passed “clearance soil testing”, the remediation action will be considered complete

ATTACHMENT #6

**CDPHE HMWMD NOTIFICATION SUMMARY AND
NOTIFICATION FORMS**

Solid Waste Notification of the Discovery of Asbestos-contaminated Soil

Program Description

Asbestos-contaminated soil may be encountered during soil-disturbing activities like underground utility installation and property redevelopment. In some cases, asbestos-containing material and/or asbestos-contaminated soils are known or suspected to be present on a property. In other cases, the site owner or operator may have no reason to know or suspect that they will encounter asbestos contamination during soil-disturbing activities. All asbestos-contaminated soil and asbestos-containing materials that are disturbed must be properly managed and disposed of in order to prevent the release of asbestos fibers into the environment.

Reporting and management of disturbed asbestos-contaminated soil and asbestos-containing material in soil may fall under either Air Quality Control Commission Regulation 8 Part B or the Regulations Pertaining to Solid Waste Disposal Sites and Facilities 6 CCR 1007-2 Section 5. If the disturbed asbestos is part of a facility component (as defined by Air Regulation 8 Part B) where the total quantity of material exceeds the trigger levels of 260 linear feet on pipes, 160 square feet on other surfaces, or the volume to be removed is greater than the volume equivalent of a 55 gallon drum, then reporting and management will be overseen by the Air Pollution Control Division of the Department of Public Health and Environment. If the disturbed asbestos is not part of a facility component, reporting and management will be governed by the Solid Waste regulations.

Who Must Notify

The person who discovers or has knowledge of the discovery of asbestos-contaminated soil must notify the Division within 24 hours of the discovery of visible material containing asbestos in soil or asbestos-contaminated soil during a soil-disturbing activity. This includes the site owner and/or operator and their representative, contractor or consultant.

The site owner and/or operator or their representative, contractor or consultant must notify the Division at least 10-working days prior to any planned soil-disturbing activity in an area of known or suspected asbestos-contaminated soil or material containing asbestos in soil.

Notification Process

In the case of an unplanned discovery of asbestos-contaminated soil during soil-disturbing activities, written notification should be faxed to 303-759-5355, sent as an attachment to email to comments.hmwmd@state.co.us, or delivered by any other means that will ensure notification is received within 24 hours. The [24-hour notification form](#) can be found on the Internet or obtained from the Division.

In the case of planned asbestos-contaminated soil-disturbing activities, written notification should be faxed to 303-759-5355, sent as an attachment to email to comments.hmwmd@state.co.us, or delivered by any other means that will ensure notification is received at least 10-working days prior to any planned soil-disturbing

activities. The [10-day notification form](#) can be found on the Internet or obtained from the Division.

Approval of Management Plan

A written Soil Characterization and Management Plan must also be submitted to the Division for review and approval at least 10-working days prior to any (additional) soil-disturbing activities. When asbestos-contaminated soil is unexpectedly encountered, appropriate immediate and interim actions must be taken to prevent release of and/or exposure to asbestos. Soil-disturbing activities cannot begin (or resume) until the Soil Characterization and Management Plan is approved.

To minimize potential delays, the site owner and/or operator may collaborate with the Division to jointly develop standard operating procedures that will be implemented as needed for all future asbestos-contaminated soil-disturbing activities. If a pre-approved plan is in place, soil-disturbing activities can proceed in accordance with these procedures once the Division has received appropriate notification.

Fees

There are no fees associated with notification. The Division will collect fees for the review of the Soil Characterization and Management Plan and related documents and for the performance of oversight activities by the Division.

Public Participation

There are no public participation requirements associated with this notification.

Guidance

[\(Draft\) Asbestos-contaminated Soil Guidance Document](#)

Forms

[24-hour Notification of Unplanned Asbestos Discovery](#)

<http://www.cdphe.state.co.us/hm/forms/asbestosnotification24hour.pdf>

[10-day Notification of Planned Asbestos Management](#)

<http://www.cdphe.state.co.us/hm/forms/asbestosnotification10day.pdf>

Statutes and Regulations

CRS 30-20-100.5 et seq.

Regulations Pertaining to Solid Waste Sites and Facilities, 6 CCR 1007-2 Section 5
Control of Hazardous Air Pollutants, 5 CCR 1001-10, Regulation 8 Part B

Division Contact

Customer Technical Assistance

Telephone 303-692-3320

Toll-free 1-888-569-1831 ext 3320

Fax 303-759-5355

Email comments.hmwm@state.co.us

Web www.cdphe.state.co.us/hm/

**Colorado Department of Public Health and Environment
Hazardous Materials and Waste Management Division
Asbestos Contaminated Soil Notification Form**

24 HOUR NOTIFICATION OF UNPLANNED ASBESTOS DISCOVERY

For 24-hour notification of the unplanned discovery of asbestos-contaminated soil, a completed a copy of this form should be faxed to 303-759-5355 Attn: Solid Waste Unit Leader, or emailed to comments.hmwm@state.co.us. If the Hazardous Materials and Waste Management Division has not pre-approved standard operating procedures that will be implemented, you must then submit a **Soil Characterization and Management Plan** to the Division for approval. If the Division has pre-approved standard operating procedures that will be implemented, you only need to submit a completed copy of this form.

The Soil Characterization and Management Plan should be mailed to: Colorado Department of Public Health and Environment, HMWMD-B2 Attn: Solid Waste Unit Leader, 4300 Cherry Creek Drive South, Denver CO 80246-1530 or emailed to: comments.hmwm@state.co.us.

Date and time reported:			
Contact person for entity performing soil-disturbing activity:		Phone:	Ext:
Organization, company or agency:			
Address:			
City:	State:	Zip:	
Name of property owner/operator or property representative:			
Owner/operator contact (if different):		Phone:	Ext:
Address:		Fax:	
City:	State:	Zip:	
Discovery date:		Discovery time (include AM or PM):	
Location of property: (Street address or other location description – e.g. highway mile marker)	Street Address:		
	County:	City:	Zip:
General Site Description:			
Activity resulting in discovery:			
Description of material encountered:			
Description of access or emissions controls implemented:			
Has the Division pre-approved standard procedures that will be implemented? <input type="checkbox"/> yes <input type="checkbox"/> no If “no,” implement interim actions and submit a Soil Characterization and Management Plan for Division review and approval.			

**Colorado Department of Public Health and Environment
Hazardous Materials and Waste Management Division
Asbestos Contaminated Soil Notification Form**

10 DAY NOTIFICATION OF PLANNED ASBESTOS MANAGEMENT

For notification of planned management of asbestos-contaminated soil, a completed copy of this form should be submitted to the Hazardous Materials and Waste Management Division at least 10 working days prior to any planned soil-disturbing activity. If the Division has not pre-approved standard operating procedures that will be implemented, you must also submit a **Soil Characterization and Management Plan** to the Division for approval. If the Division has pre-approved standard operating procedures that will be implemented, then you only need to submit a completed copy of this form.

The form and plan can be mailed to: Colorado Department of Public Health and Environment, HMWMD-B2 Attn: Solid Waste Unit Leader, 4300 Cherry Creek Drive South, Denver CO 80246-1530
or emailed to: comments.hmwmd@state.co.us .

Date and time reported:			
Contact person for entity performing soil-disturbing activity:		Phone:	Ext:
Organization, company or agency:			
Address:			
City:	State:	Zip:	
Name of property owner/operator or property representative:			
Owner/operator contact (if different):		Phone:	Ext:
Address:		Fax:	
City:	State:	Zip:	
Location of property: (Street address or other location description – e.g. highway mile marker)	Street Address:		
	County:	City:	Zip:
General Site Description:			
Description of planned soil-disturbing activities:			
Description of material that will be disturbed:			
Has the Division pre-approved standard procedures that will be implemented? <input type="checkbox"/> yes <input type="checkbox"/> no If “no,” submit a Soil Characterization and Management Plan for Division review and approval.			

STATE OF COLORADO

Bill Ritter, Jr., Governor
Martha E. Rudolph, Executive Director

Dedicated to protecting and improving the health and environment of the people of Colorado

4300 Cherry Creek Dr. S. Laboratory Services Division
Denver, Colorado 80246-1530 8100 Lowry Blvd.
Phone (303) 692-2000 Denver, Colorado 80230-6928
TDD Line (303) 691-7700 (303) 692-3090
Located in Glendale, Colorado

<http://www.cdphe.state.co.us>



Colorado Department
of Public Health
and Environment

April 28, 2010

Mr. Ken Neeper
Manager Infrastructure Development
University of Colorado Denver
Mail Stop F418
1945 North Wheeling Street
Aurora, CO 80045

RE: Asbestos-Contaminated Soil (ASC) Management, Standard Operating Procedure (SOP) Document, University of Colorado Denver Anschutz Medical Campus, February 26, 2010

Dear Mr. Neeper,

The Colorado Department of Public Health and Environment, Hazardous Materials and Waste Management Division (the "Division"), has received and reviewed the above referenced standard operating procedures for the proper management of asbestos-contaminated soils during soil disturbing activities at the Anschutz Medical Campus of the University of Colorado Denver. The Anschutz Medical Campus is located on the site of the former Fitzsimons Army medical Center in Aurora, Colorado. The Division has no additional comments and hereby approves the Anschutz Medical Campus ACS Management SOP Document.

If you have any further questions or comments please contact me at 303-692-3416 or via e-mail at jeffrey.swanson@state.co.us.

Sincerely,

Jeffrey R. Swanson, P.E.
Federal Facilities Restoration and Reuse Unit
Remedial Program

CC: Tom Butts, Walsh Environmental Scientists and Engineers
Monica Sheets, CDPHE
Rob Eber, AGO
File Copy: RD007-13.1